



---

## MULTIFUNCTIONAL STATION 4

---

### OWNER'S MANUAL

WEBSITE



MANUAL



**DKN**®

# MULTI 4 STATION (FUNCTION ABCEF)

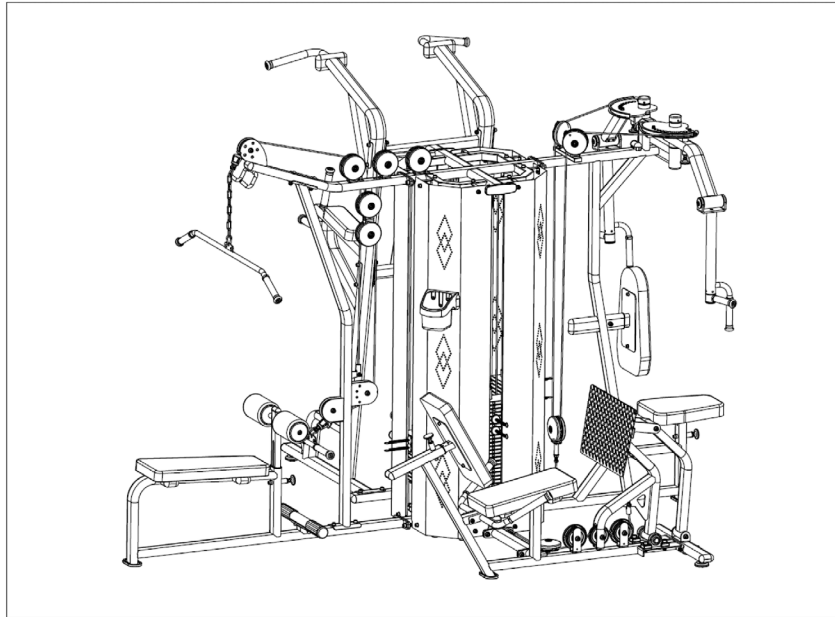

Serial	Function	Serial	Function
A	Standard	E	Horizontal and Parallel Bars Set
B	High Low Pull Set	F	Unilateral Fly Set
C	Chest Fly Set	G	Seated Chest Press Set
D	Leg Press Set		

1: Because Function B is one of the Standard Function. So Function B can only be assembled at I (Do NOT install at II、III、IV)

2: Function CDEFG are option function. Choose three function and Assemble at II、III、IV base on the interest of consumer (Do NOT install at I )

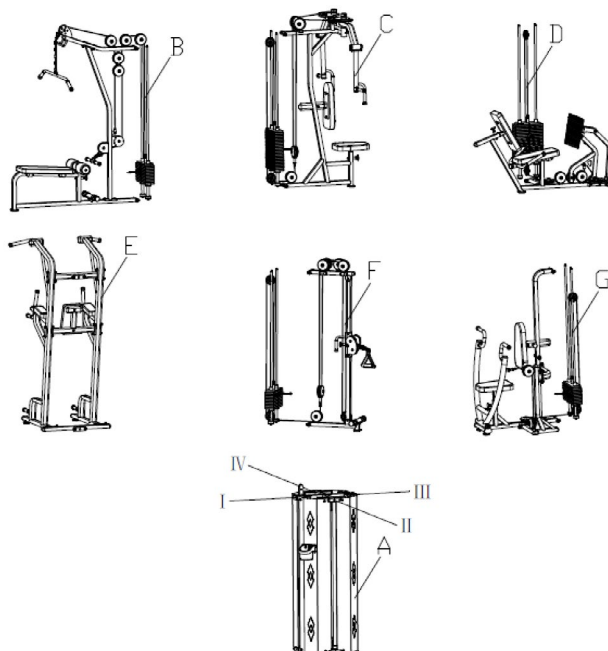

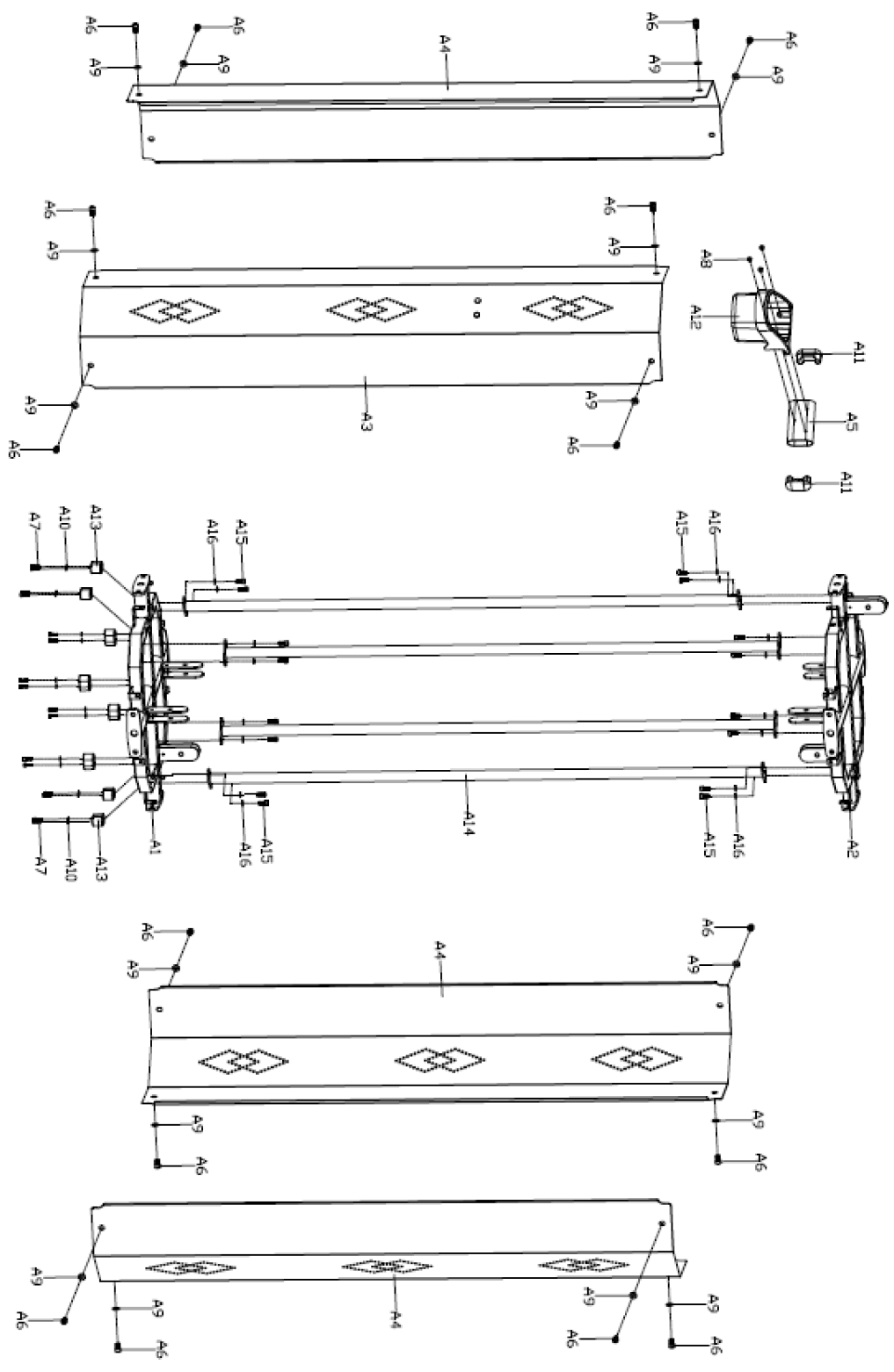

Function A explosive view

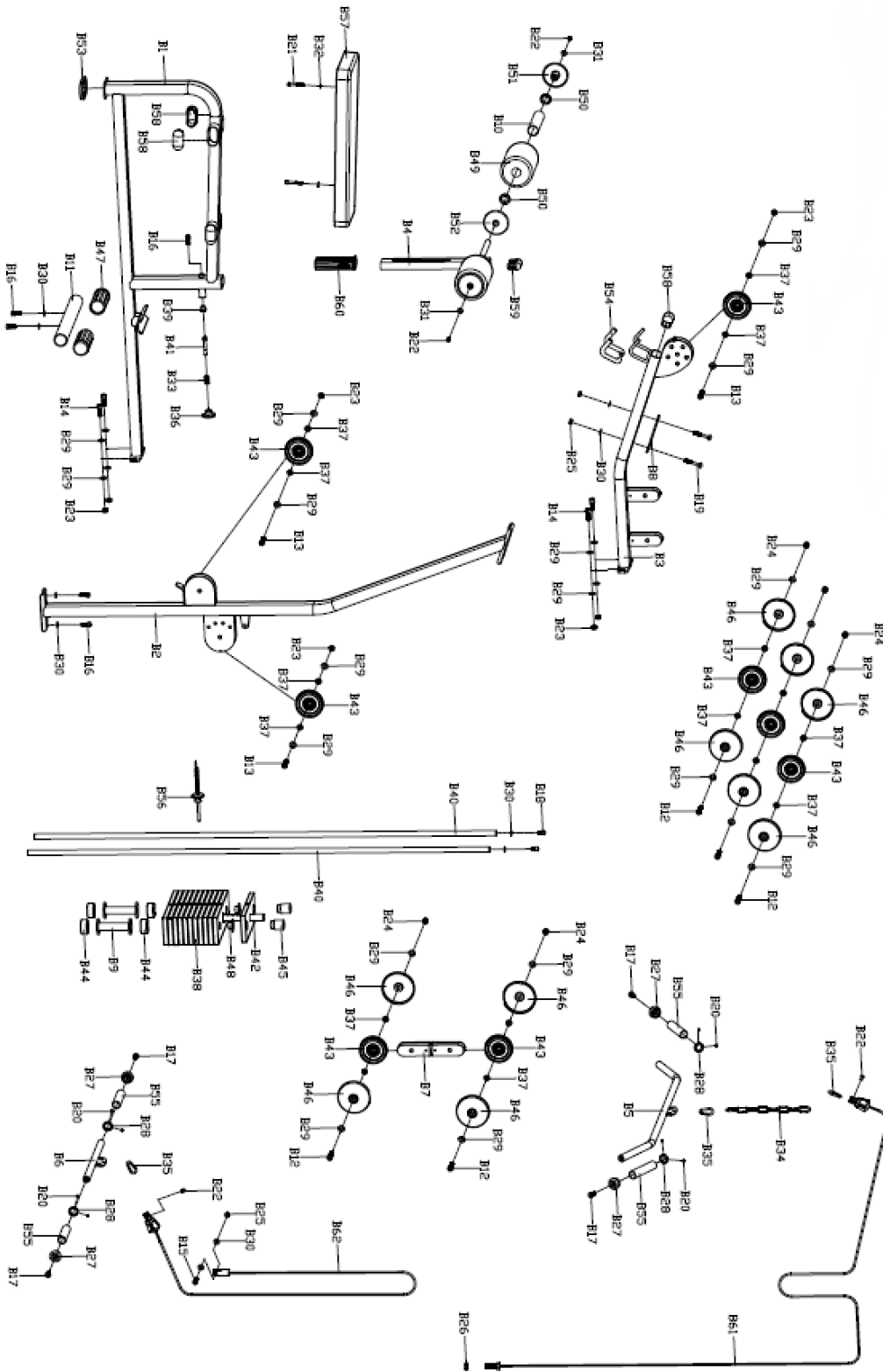

Function B explosive view

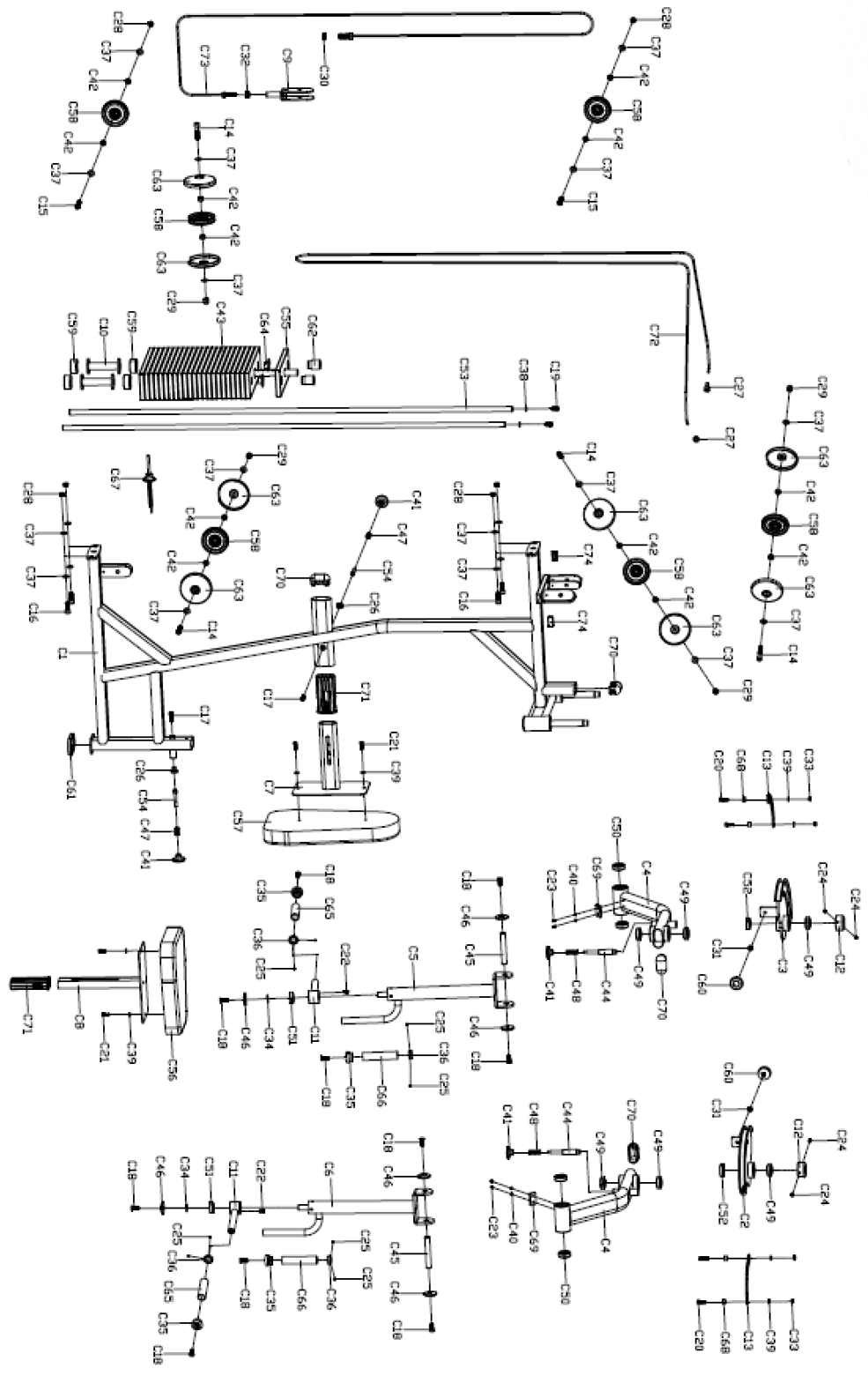

Function C explosive view

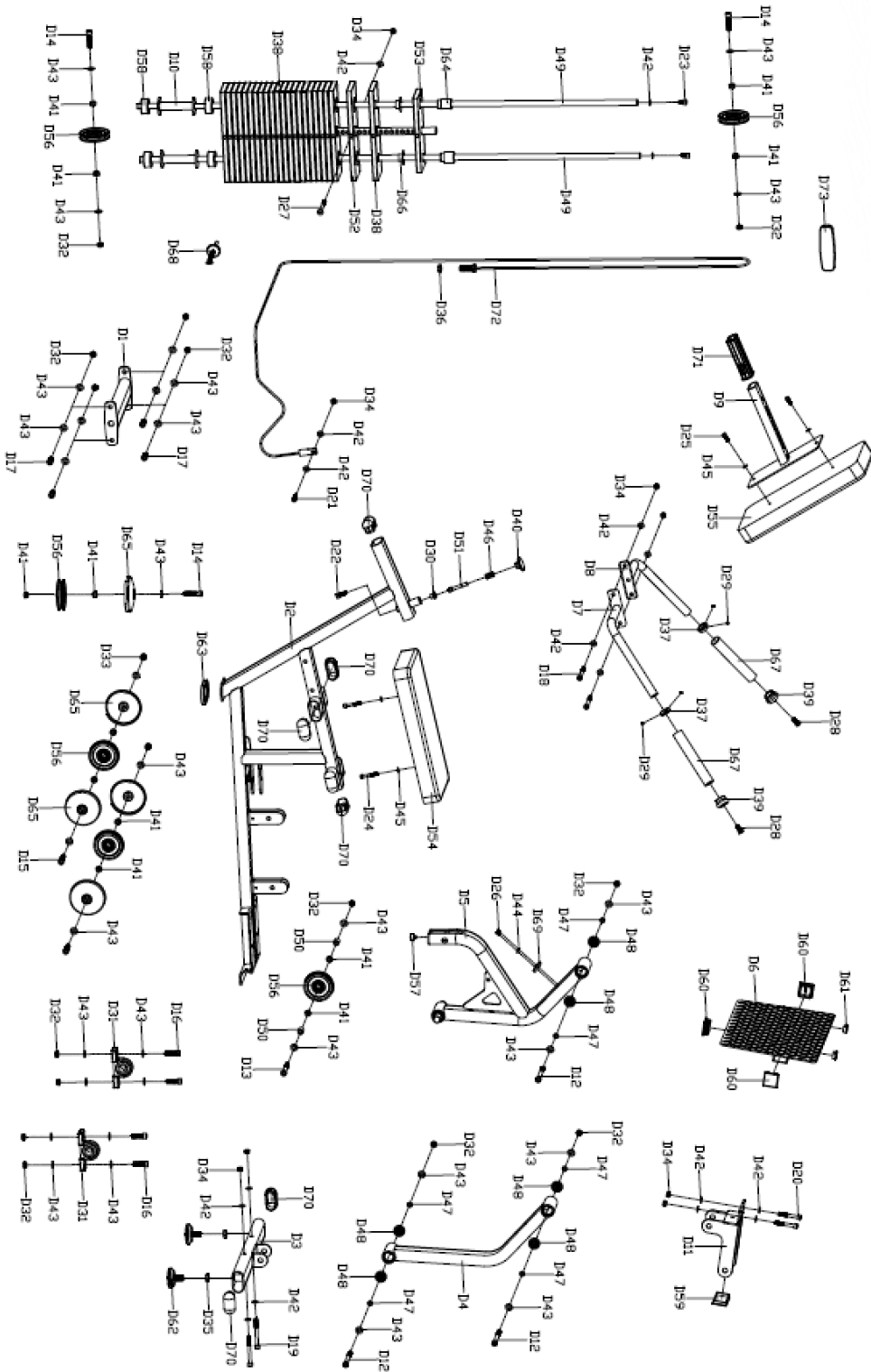

Function D explosive view

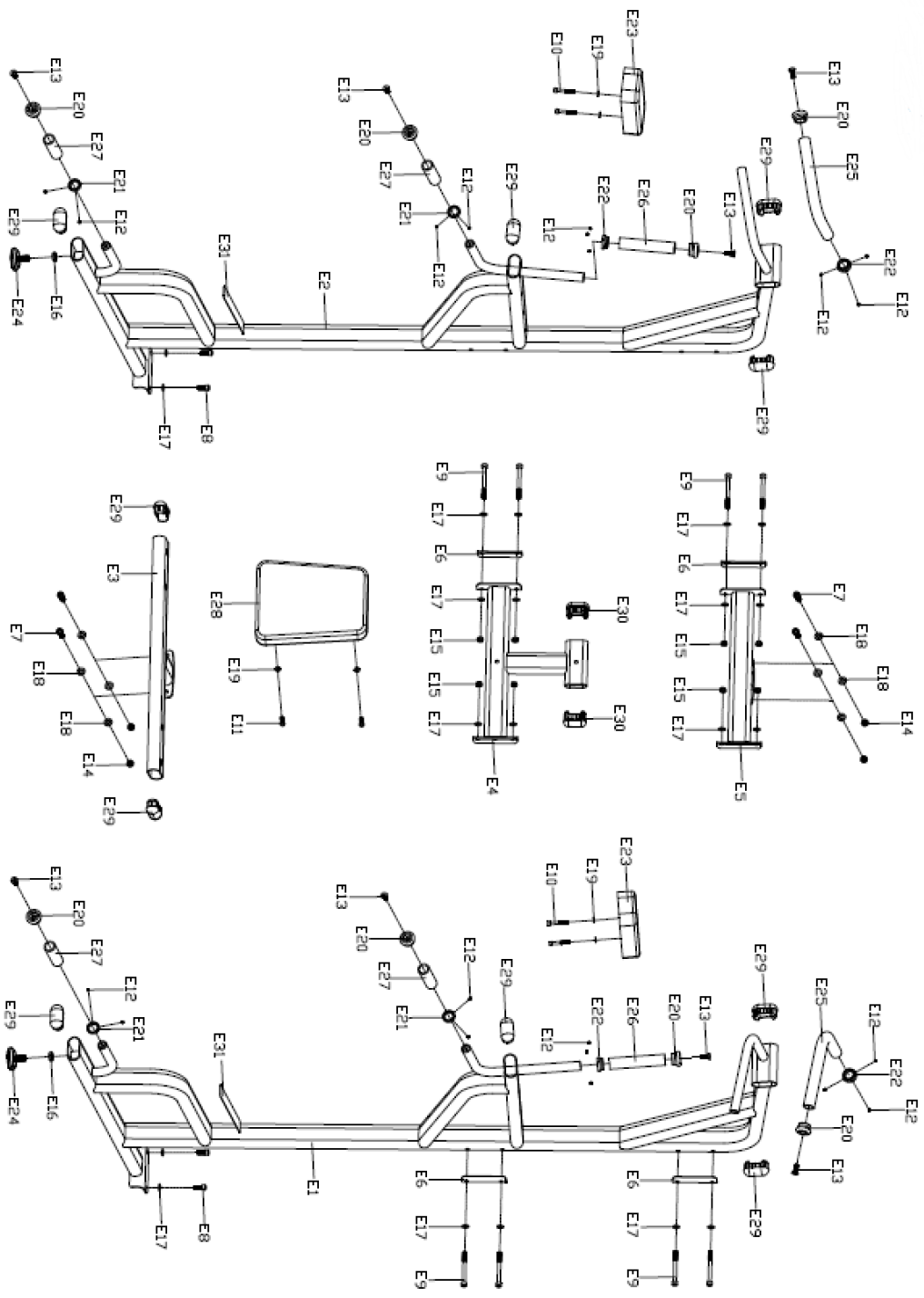

Function E explosive view

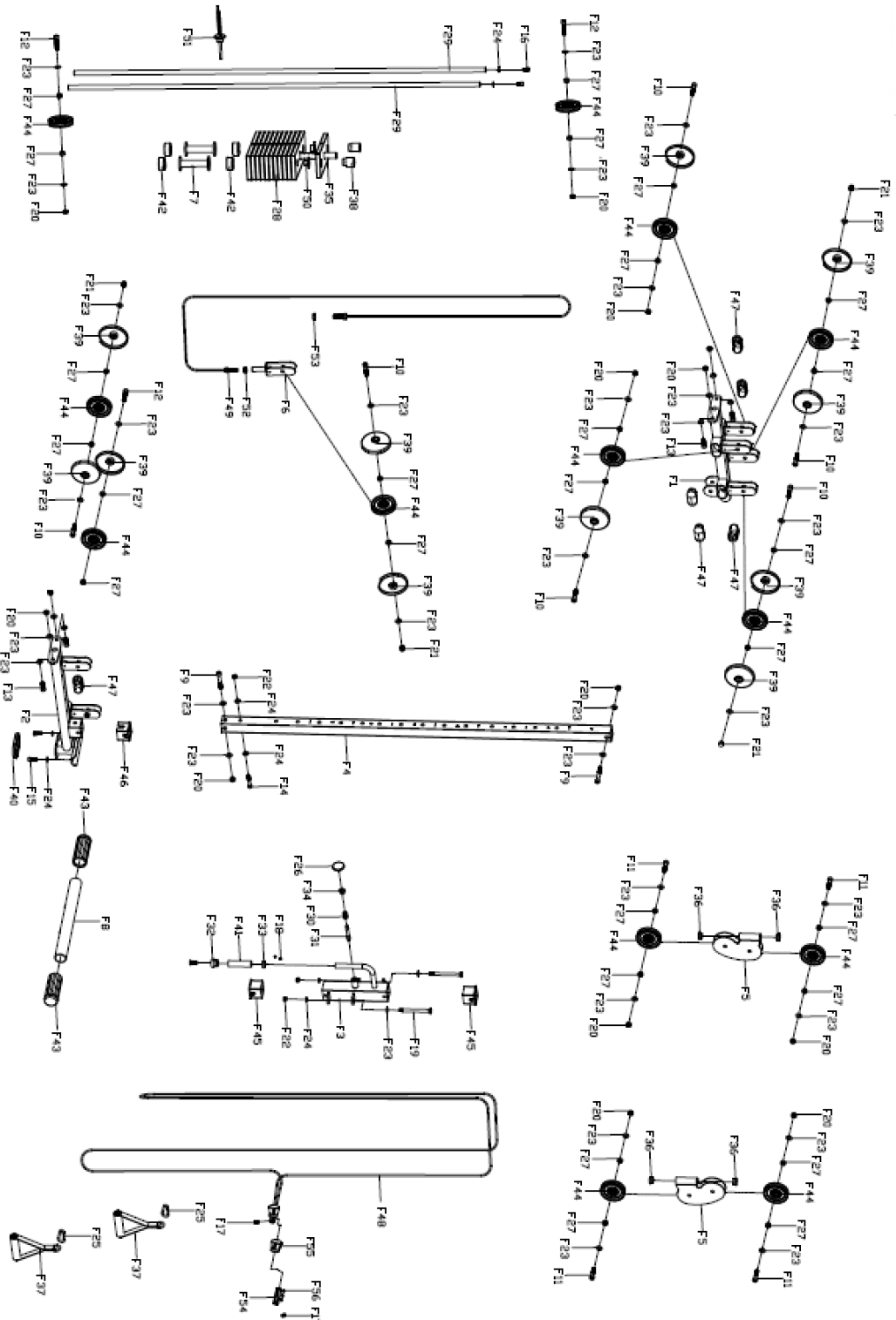

Function F explosive view (OPTIONAL FUNCTION)



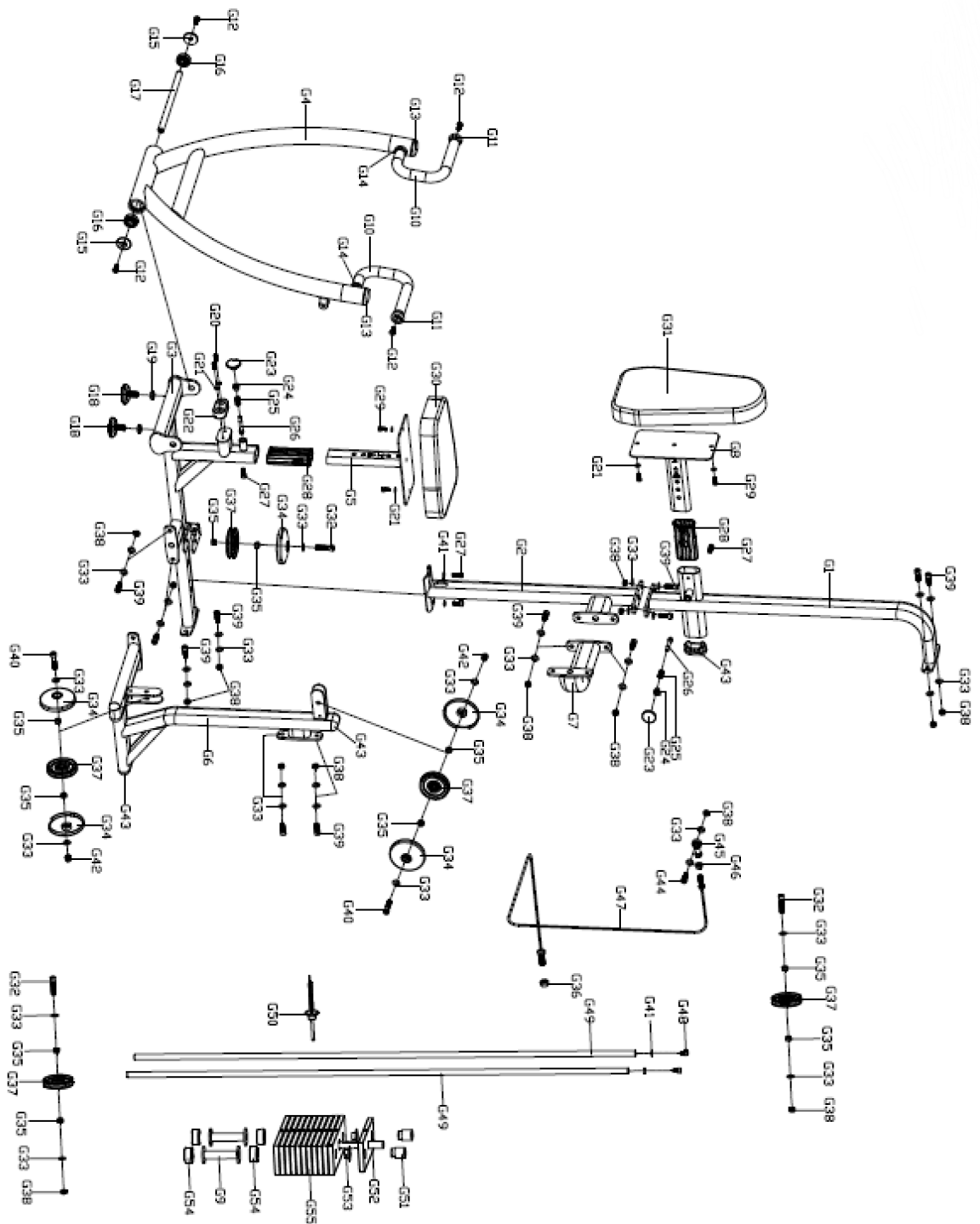

Function G explosive view (OPTIONAL FUNCTION)

Function A Part List					
Serial	Item	Quantity	Serial	Item	Quantity
A1	Bottom Seat Combo	1	A9	Flat Washer D10*D20*2	16
A2	Above Seat Combo	1	A10	Flat Washer $\phi 12 * \phi 6 * 1.2$	16
A3	Cover Combo	1	A11	Stopper 80*40*2	2
A4	Cover	3	A12	Water Bottle	1
A5	Shelf Tube	1	A13	Carsh Pad	8
A6	Hexagon bolt	16	A14	Supporting Tube Combo	4
A7	Hexagon bolt	16	A15	Hexagon bolt	16
A8	Cross Screw M6*15	3	A16	Flat Washer D8*D16*2	16

Function B Part List					
Serial	Item	Quantity	Serial	Item	Quantity
B1	Main Seat frame	1	B32	Flat Washer D8*D16*1.5	2
B2	Main Base frame	1	B33	Junk ring	1
B3	Cant Beam frame	1	B34	Chain	1
B4	Leg Adjusting frame	1	B35	Hook	3
B5	Long handle	1	B36	Pull-tab	1
B6	Short handle	1	B37	Alloy sleeve	16
B7	U Shape clevis	1	B38	Weight block	11
B8	Connector	1	B39	Bolt tube nut	1
B9	Top tube	2	B40	Slide bar	2
B10	Foam tube	2	B41	Bolt	1
B11	Foot support frame	1	B42	Rod	1
B12	Hexagon bolt M12*55	5	B43	Pulley	8
B13	Hexagon bolt M12*52	3	B44	Crash pad	4
B14	Hexagon bolt M12*32	4	B45	Nylon sleeve	2
B15	Hexagon bolt M10*38	1	B46	Pulley cover	10
B16	Hexagon bolt M10*25	5	B47	$\phi 50$ tube sleeve	2
B17	Hexagon screw M10*30	4	B48	Nylon flange sleeve	22
B18	Hexagon bolt M10*16	2	B49	Foam	2
B19	Square bolt M10*65	2	B50	Axle sleeve	4
B20	Hexagon screw M5*4	8	B51	Foam outer cap	2
B21	Hexagon bolt M8*55	2	B52	Foam inner cap	2

B22	Hexagon bolt M8*20	4	B53	Rubber obver	1
B23	Nylon nut M12	7	B54	Dip plastic handle set φ9*φ16*160	2
B24	High cover nut M12	5	B55	Dip plastic handle set φ24*φ31*140	4
B25	Nylon nut M10	3	B56	Magnetic bolt	1
B26	Hexagon nut M16	1	B57	Seat	1
B27	Aluminum cover	4	B58	Stopper 80*40*2.5	5
B28	Handle ring	4	B59	Stopper 70*30*2.5	1
B29	Flat Washer D12*D24*2	24	B60	Seat sleeve	1
B30	Flat Washer D10*D20*2	10	B61	High pull down rope	1
B31	Flat Washer D8*D20*2	2	B62	Low row rope	1

## Function C Part List

Serial	Item	Quantity	Serial	Item	Quantity
C1	Upper frame	1	C38	Flat Washer D10*D20*2	2
C2	Right Guide cam	1	C39	Flat Washer D8*D16*1.5	8
C3	Left Guide cam	1	C40	Flat Washer D5*D10*1	4
C4	Upper fly arm	2	C41	Pull-tab	4
C5	Left Butterfly arm	1	C42	Alloy sleeves	12
C6	Right Butterfly arm	1	C43	Weight block	23
C7	Backrest post	1	C44	Bolt φ20*133	2
C8	Seat post	1	C45	Minor axis	2
C9	Pulley bracket	1	C46	End cap	6
C10	Jacking joint	2	C47	Pressure spring Φ14*Φ1.2*L28	2
C11	Deltoid fly handle	2	C48	Pressure spring Φ16*Φ14*L46	2
C12	Collar block	2	C49	Bearing 6005-2rs	6
C13	Guide plate limit	2	C50	Bearing 6204	4
C14	Hexagon bolt M12*55	4	C51	Bearing 6004	2
C15	Hexagon bolt M12*52	2	C52	Bearing 6005	2
C16	Hexagon bolt M12*32	4	C53	Slider	2
C17	Hexagon bolt M10*25	2	C54	Bolt φ14.4*73	2
C18	Hexagon screw M10*30	10	C55	Pull rod	1
C19	Hexagon bolt M10*16	2	C56	Seat	1
C20	Hexagon bolt M8*25	4	C57	Backrest	1
C21	Hexagon bolt M8*20	4	C58	Pulley	6
C22	Hexagon bolt M6*12	2	C59	Crash pad	4
C23	Cross screw M4*12	4	C60	Adjustable foot support	2

C24	Hexagon screw M8*16	4	C61	Rubber foot support	1
C25	Hexagon screw M5*4	8	C62	Nylon sleeve	2
C26	Bolt tube nut	2	C63	Pulley cover	8
C27	Rope fix sleeve	2	C64	Nylon flange sleeve	46
C28	Nylon nut M12	6	C65	Dip plastic handle set φ24*φ31*105	2
C29	High cover nut M12	4	C66	Dip plastic handle set φ24*φ31*140	2
C30	Hexagon nut M16	1	C67	Magnetic bolt	1
C31	Hexagon nut M10	2	C68	Crash sleeve	4
C32	Flange nut M12	1	C69	Distance rubber pad	2
C33	Nylon nut M8	4	C70	Stopper	4
C34	Wave WasherΦ 20×Φ26×0.3	2	C71	Saddle sleeve	2
C35	Aluminum cover	4	C72	Arm rope	1
C36	Handle ring	4	C73	Connect rope	1
C37	Flat Washer D12*D24*2	20	C74	Square stopper	2

Function D Part List					
Serial	Item	Quantity	Serial	Item	Quantity
D1	Connecting tube	1	D38	Weight block 1	22
D2	Seat tube	1	D39	Aluminum cover	2
D3	Front base Frame	1	D40	Pull-tab	1
D4	Front Connecting tube	1	D41	Alloy sleeve	12
D5	Rear connecting tube	1	D42	Flat Washer D10*D20*2	17
D6	Foot support	1	D43	Flat Washer D12*D24*2	33
D7	Right handle	1	D44	Flat Washer D5*D10*1	2
D8	Left handle	1	D45	Flat Washer D8*D16*1.5	4
D9	Backrest tube	1	D46	Pressure spring	1
D10	Top cap	2	D47	Spacer bush φ12.2*φ16*6	6
D11	Foot support connecting tube	1	D48	Bearing 6201	6
D12	Hexagon bolt M12*125	3	D49	Slider	2
D13	Hexagon bolt M12*95	1	D50	Spacer bush φ12.2*φ18*28	2
D14	Hexagon bolt M12*52	3	D51	Bolt	1
D15	Hexagon bolt M12*55	2	D52	Weight block 2	1
D16	Hexagon bolt M12*40	4	D53	Pull rod	1
D17	Hexagon bolt M12*32	4	D54	Seat	1
D18	Hexagon bolt M10*105	2	D55	Backrest	1
D19	Hexagon bolt M10*100	2	D56	Pulley	6
D20	Hexagon bolt M10*70	2	D57	Crash pad φ25*20	1
D21	Hexagon bolt M10*38	1	D58	Crash pad	4
D22	Hexagon bolt M10*25	1	D59	Square stopper 100*50*2	1

D23	Hexagon bolt M10*16	2	D60	Square stopper 50*50*2.5	3
D24	Hexagon bolt M8*55	2	D61	Square stopper 25*25*2	2
D25	Hexagon bolt M8*20	2	D62	Adjustable foot support	2
D26	Cross screw M4*10	2	D63	Rubber foot support	1
D27	Hexagon screw M10*125	1	D64	Nylon sleeve	2
D28	Hexagon screw M10*30	2	D65	Pulley cover	5
D29	Hexagon screw M5*4	4	D66	Nylon flange sleeve	46
D30	Bolt tube nut	1	D67	Dip plastic handle set	2
D31	Bearing	2	D68	Magnetic bolt	1
D32	Nylon nut M12	14	D69	Distance rubber pad	1
D33	High cover nut M12	2	D70	Stopper	7
D34	Nylon nut M10	8	D71	Saddle sleeve	1
D35	Hexagon nut M16*1.5	2	D72	Rope	1
D36	Hexagon nut M16	1	D73	Rubber foot support	1
D37	Handle ring	2			









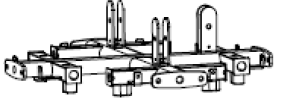
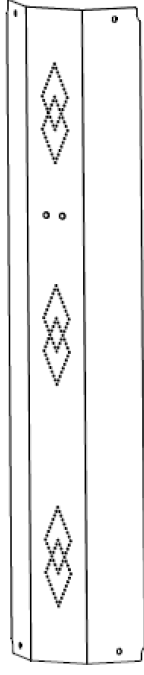

## Function E Part List

Serial	Item	Quantity	Serial	Item	Quantity
E1	Left tube	1	E17	Flat Washer D10*D20*2	20
E2	Right tube	1	E18	Flat Washer D12*D24*2	8
E3	Bottom tube	1	E19	Flat Washer D8*D16*1.5	6
E4	Middle tube	1	E20	Aluminum cap	8
E5	Upper tube	1	E21	Handle ring	4
E6	Arc splicing	4	E22	Aluminum spacer	4
E7	Hexagon bolt M12*32	4	E23	Handguard	2
E8	Hexagon bolt M10*25	4	E24	Adjustable foot pad	2
E9	Hexagon bolt M10*105	8	E25	Dip plastic handle set φ27*φ35*410	2
E10	Hexagon bolt M8*55	4	E26	Dip plastic handle set φ27*φ35*175	2
E11	Hexagon bolt M8*45	2	E27	Dip plastic handle set φ27*φ35*120	4
E12	Hexagon screw M5*4	20	E28	Backrest	1
E13	Hexagon screw M10*30	8	E29	Stopper 80*40*2.5	10
E14	Nylon nut M12	4	E30	Stopper 70*30*2.5	2
E15	Nylon nut M10	8	E31	Non-slip mat	2
E16	Hexagon nut M6	2			

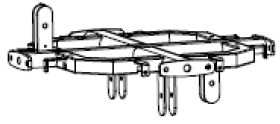
Function F Part List (OPTIONAL FUNCTION)					
Serial	Item	Quantity	Serial	Item	Quantity
F1	Upper tube	1	F29	Slider	2
F2	Bottom tube	1	F30	Pressure spring	1
F3	Adjustable tube	1	F31	Bolt	1
F4	Slip tube	1	F32	Aluminum cap	1
F5	Guide plate	2	F33	Handle ring	1
F6	Pulley bracket	1	F34	Bolt tube nut	1
F7	Top cap tube	2	F35	Pull rod	1
F8	Foot pedal tube	1	F36	Axis Sleeve	4
F9	Hexagon bolt M12*80	2	F37	Ribbon handle 1	2
F10	Hexagon bolt M12*55	6	F38	Nylon Axis Sleeve	2
F11	Hexagon bolt M12*50	4	F39	Pulley cover	11
F12	Hexagon bolt M12*52	3	F40	Rubber foot support	1
F13	Hexagon bolt M12*32	4	F41	Dip plastic handle set	1
F14	Hexagon bolt M10*60	1	F42	Crash pad	4
F15	Hexagon bolt M10*25	2	F43	φ 50 Pipe sleeve	2
F16	Hexagon bolt M10*16	2	F44	Pulley	13
F17	Hexagon bolt M8*20	2	F45	Sleeve 1	2
F18	Hexagon screw M5*4	2	F46	Sleeve 2	1
F19	Outer hexagon bolts φ12*M10*132	2	F47	End cap	6
F20	Nylon nut M12	14	F48	Rope lock	1
F21	High cover nut M12	4	F49	Connect rope	1
F22	Nylon nut M10	3	F50	Nylon flange sleeve	22
F23	Flat Washer D12*D24*2	39	F51	Magnetic bolt	1
F24	Flat Washer D10*D20*2	8	F52	Flange nut M12	1
F25	Hook	2	F53	Hexagon nut M16	1
F26	Pull-tab	1	F54	Hexagon rope block	2
F27	Alloy sleeve	26	F55	Rope rubber cap	2
F28	Weight block	11	F56	Hexagon bolt	6

Function G Part List (OPTIONAL FUNCTION)					
Serial	Item	Quantity	Serial	Item	Quantity
G1	Upper tube	1	G29	Hexagon bolt M8*20	4
G2	Bottom tube	1	G30	Seat	1
G3	Seat tube	1	G31	Backrest	1
G4	Arm tube	1	G32	Hexagon screw M12*52	3
G5	Seat adjusting tube	1	G33	Flat Washer D12*D24*2	35
G6	Connecting tube	1	G34	Pulley cover	5
G7	Top tube	1	G35	Alloy sleeve	10

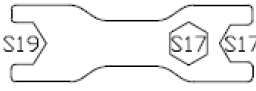
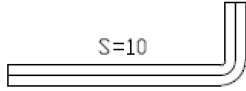
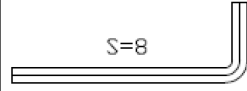

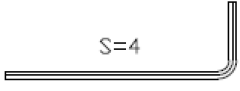
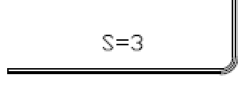
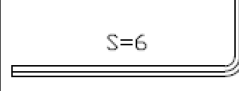
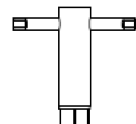







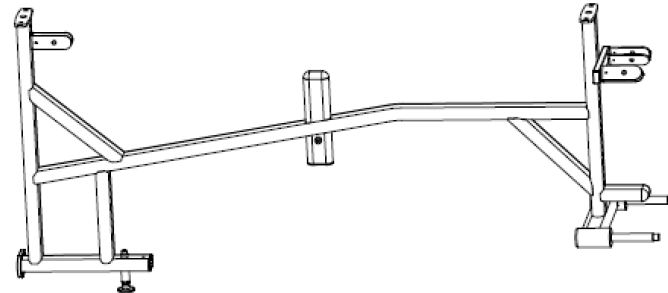

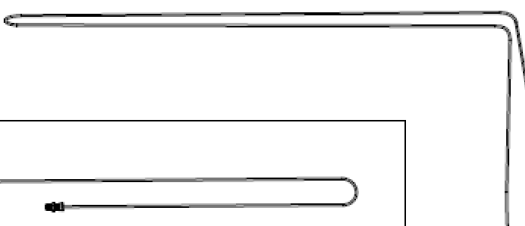

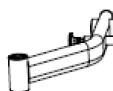

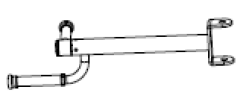









G8	Backrest adjusting tube	1	G36	Hexagon nut M16	1
G9	Top cap tube	2	G37	Pulley	5
G10	Dip plastic handle set	2	G38	Nylon nut M12	15
G11	Aluminum cap	2	G39	Hexagon bolt M12*32	12
G12	Hexagon bolt M10*30	4	G40	Hexagon bolt M12*55	2
G13	Stopper	2	G41	Flat Washer D10*D20*2	4
G14	Aluminum sleeve	2	G42	High cover nut M12	2
G15	End cap	2	G43	Stopper	4
G16	Bearing 6204	2	G44	Hexagon bolt M12*45	1
G17	Long axis	1	G45	Bearing	1
G18	Adjustable foot padel	2	G46	Flange nut M12	1
G19	Hexagon nut M16*1.5	2	G47	Rope	1
G20	Hexagon bolt M8*20	2	G48	Hexagon bolt M10*16	2
G21	Flat Washer D8*D16*1.5	4	G49	Slider	2
G22	Crash pad 88*44*26	1	G50	Magnetic bolt	1
G23	Pull-tab	2	G51	Nylon Axis Sleeve	2
G24	Bolt tube nut	2	G52	Pull rod	1
G25	Pressure spring	2	G53	Nylon flange sleeve	22
G26	Bolt	2	G54	Crash pad Φ55*Φ21*25	4
G27	Hexagon bolt M10*25	4	G55	Weight block	11
G28	Saddle sleeve	2			

				
<p>#A1 1PC</p>			<p>#A12 1PC</p>	
				
<p>#A2 1PC</p>	<p>#A8 3PCS</p>			
		<p>#A9 16PCS</p>		
<p>#A5 1PC</p>	<p>#A3 1PC</p>	<p>#A4 3PCS</p>	<p>#A6 16PCS</p>	<p>#A14 4PCS</p>
				
<p>1PC</p>	<p>1PC</p>	<p>1PC</p>	<p>#A15 16PCS</p>	<p>#A16 16PCS</p>
				
<p>1PC</p>	<p>1PC</p>	<p>1PC</p>	<p>1PC</p>	





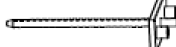

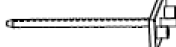
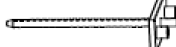
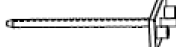
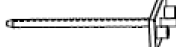
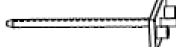
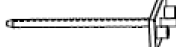
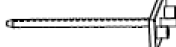
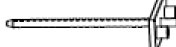
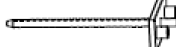
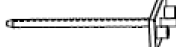
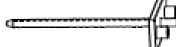
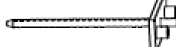
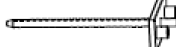
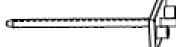
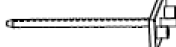
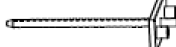
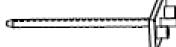
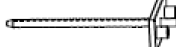
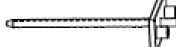
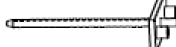
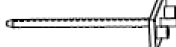
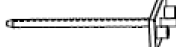
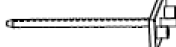
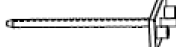
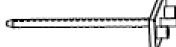
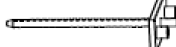
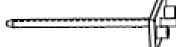
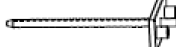
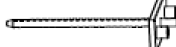
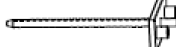
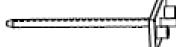
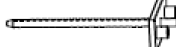
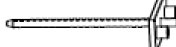
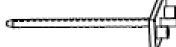
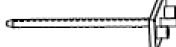
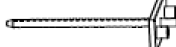
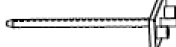
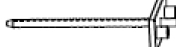
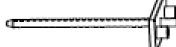
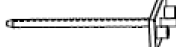
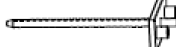
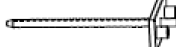
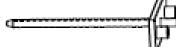
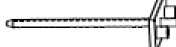
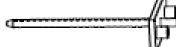
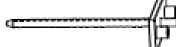
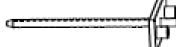
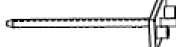
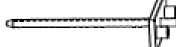
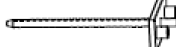
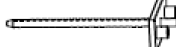
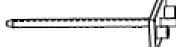
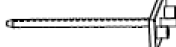
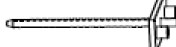
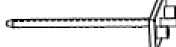
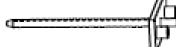
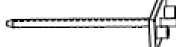
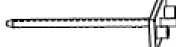
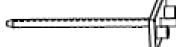
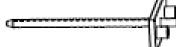
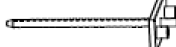
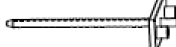
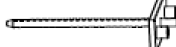
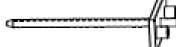
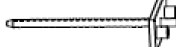
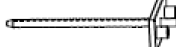



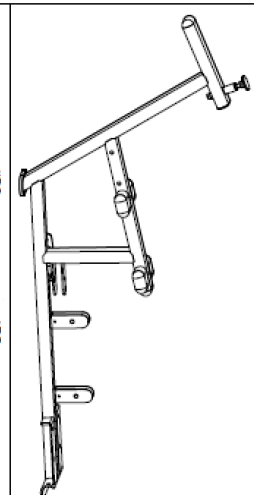



















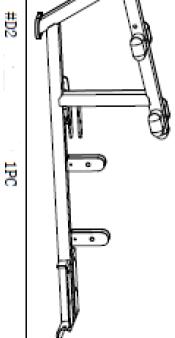













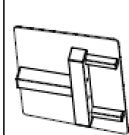















Function A

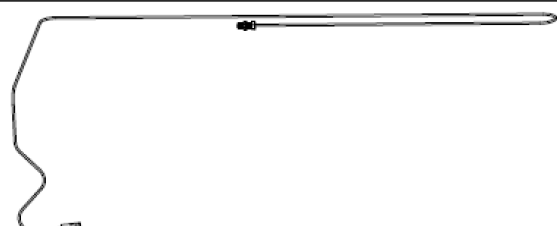





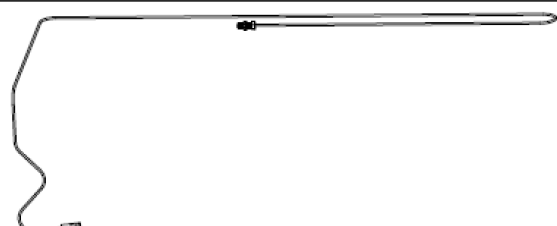





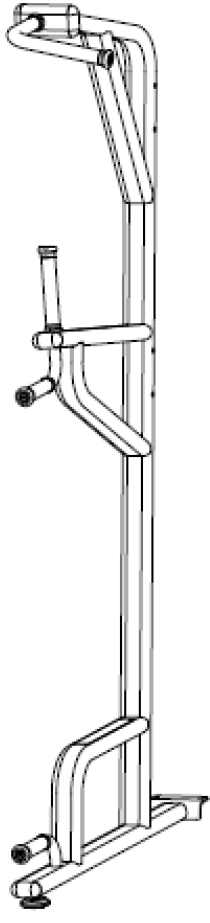
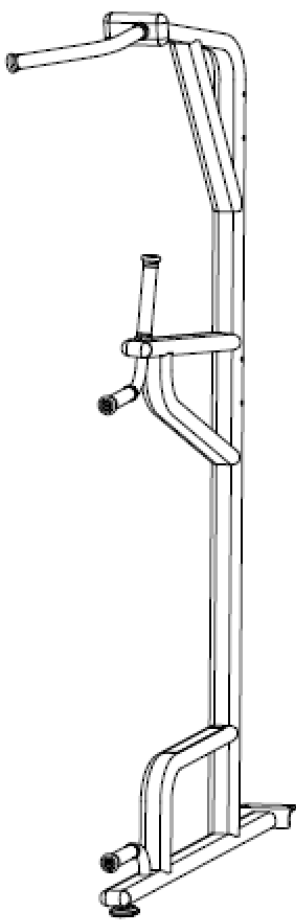

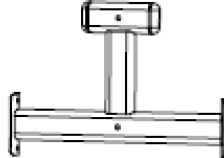



				#C2	1PC	#C10	2PCS	#C14	4PCS	#C27	2PCS	#C43	23PCS		
				#C3	1PC	#C12	2PCS	#C15	2PCS	#C28	6PCS	#C45	2PCS		
				#C5	1PC			#C16	4PCS	#C29	6PCS	#C46	4PCS		
				#C7	1PC			#C18	4PCS	#C37	20PCS	#C56	1PC		
				#C8	1PC			#C19	2PCS	#C38	2PCS	#C57	1PC		
				#C9	1PC			#C21	4PCS	#C39	4PCS	#C63	8PCS		
				#C10	2PCS			#C24	4PCS	#C42	12PCS	#C67	1PC		
				#C11	1PC			#C27	2PCS	#C44	12PCS				
				#C12	2PCS			#C31	4PCS	#C46	4PCS				
				#C13	2PCS			#C38	2PCS	#C48	12PCS				
				#C14	2PCS			#C42	12PCS	#C50	6PCS				
				#C15	2PCS			#C45	2PCS	#C53	6PCS				
				#C16	4PCS			#C49	6PCS	#C56	1PC				
				#C17	2PCS			#C54	2PCS	#C59	4PCS				
				#C18	4PCS			#C60	4PCS	#C63	8PCS				
				#C19	2PCS			#C64	4PCS	#C67	1PC				
				#C20	4PCS			#C68	4PCS	#C70	1PC				
				#C21	4PCS			#C71	1PC	#C73	1PC				
				#C22	2PCS			#C72	1PC						
				#C23	4PCS			#C73	1PC						

Function C















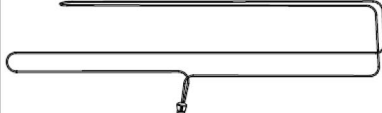







													
													
													
													
													
													
													
													
													

Function D

			
		#E3 1PC	#E7 4PCS
			
		#E4 1PC	#E8 4PCS
			
#E5 1PC	#E9 8PCS		
#E1 1PC	#E2 1PC	#E6 4PCS	#E10 4PCS
			
#E28 1PC	#E18 8PCS	#E15 8PCS	#E11 2PCS
			
#E23 2PCS	#E19 6PCS	#E17 20PCS	#E14 4PCS

Function E

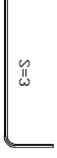
**NOTE:** It is well suggested that two or more people to assemble this machine to avoid any possible injury. Remove all the security tape and wrapping before the installation. Please refer the individual steps for the installation and pay attention to the preinstalled hardware.

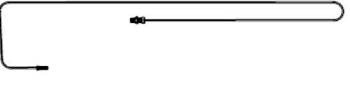
#F1	1PC	#F29	2PCS	#F3	1PC	#F8	1PC	#F35	1PC	#F52	1PCS	#F18	1PC
													
#F20	1PCS	#F23	3PCS	#F9	2PCS	#F13	4PCS	#F12	4PCS	#F54	1PC		
													
#F21	4PCS	#F24	4PCS	#F10	6PCS	#F11	4PCS	#F12	3PCS	#F55	1PC		
													
#F37	2PCS	#F39	11PCS	#F15	2PCS	#F16	2PCS		1PC	#F56	3PCS	#F19	1PC
													

Function F



## Function A:

### Step 1 (this step has direction distinction, please follow the diagram)

1. Attach the Supporting Tube Combo (A14) to Bottom Seat Combo (A1) and Above Seat Combo (A2) with Hexagon bolt (A15), Flat washers (A16) as shown.

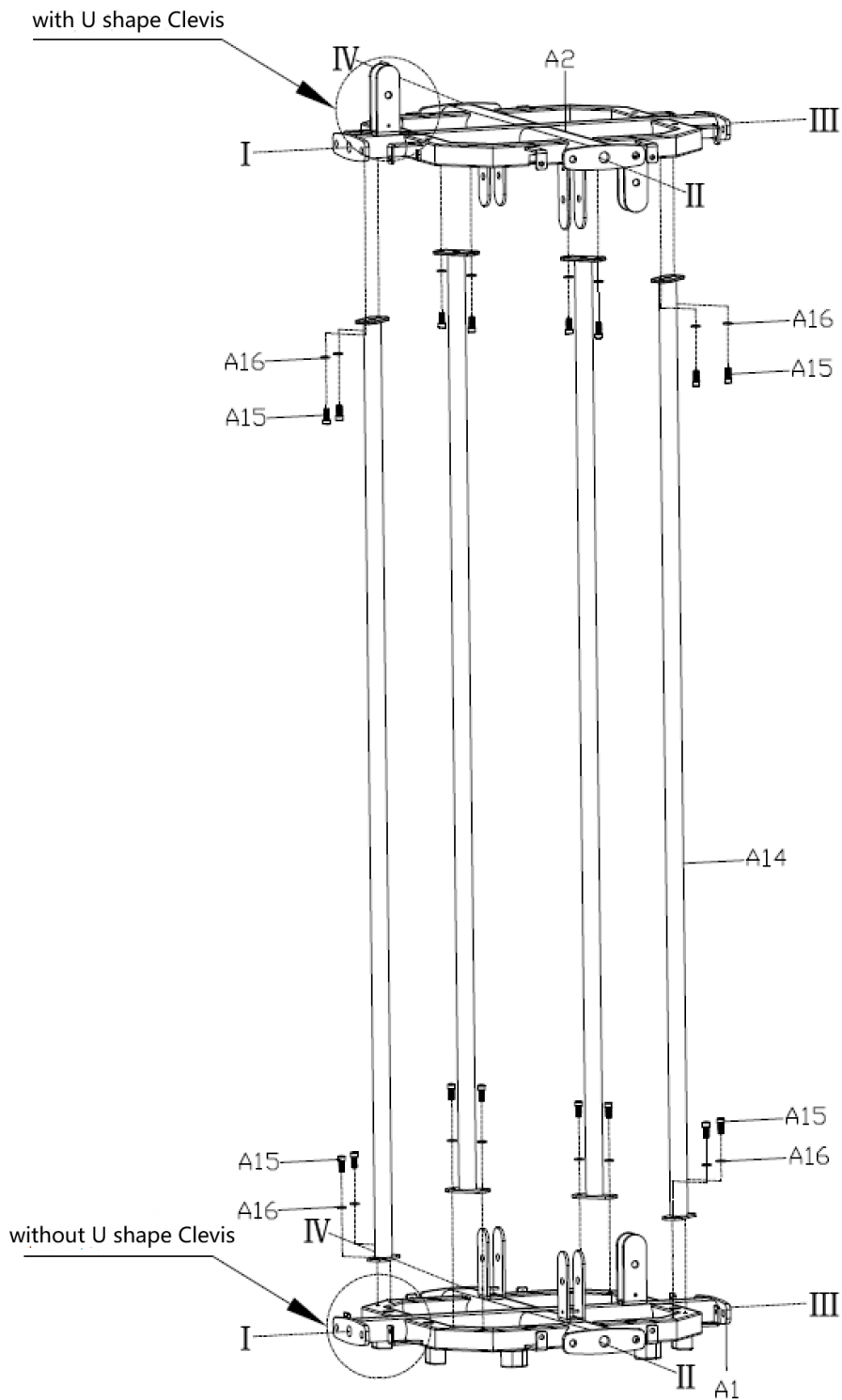

**Function A :**

**Step 2 (note: Function B is one of the Standard Function, CDEFG functions, guests can choose three packed function to section A base on guests' requirement. Function B can only be installed At I, CDEFG can be installed at II, III, IV as optional function) :**

**Section B Weight block:** Attach Slide bar (B40) to bottom seat (A1), then put in follow parts in the right order: Crash pad (B44). Top tube (B9), Weight block (B39), Rod (B42) onto (B40). Then attach (B40) to Upper seat (A2) with Hexagon bolt (B18) and Flat washer (B30).

**Section C Weight block:** Attach Slide bar (C53) to bottom seat (A1), then put in follow parts in the right order: Crash pad (C59). Top tube (C10), Weight block (C43), Rod (C55) onto (C53). Then attach (C53) to Upper seat (A2) with Hexagon bolt (C19) and Flat washer (C38) .

**Section D Weight block:** Attach Slide bar (D49) to bottom seat (A1), then put in follow parts in the right order: Crash pad (D58). Top tube (D10), Weight block 1 (D38), Weight block 2 (D52), Rod(D53) onto (D49). Then attach Hexagon screw (D27), Flat washer (D42) and Nylon nut (D34) on (D52), attach (D49) to Upper seat (A2) with Hexagon bolt (D23) and Flat washer (D42).

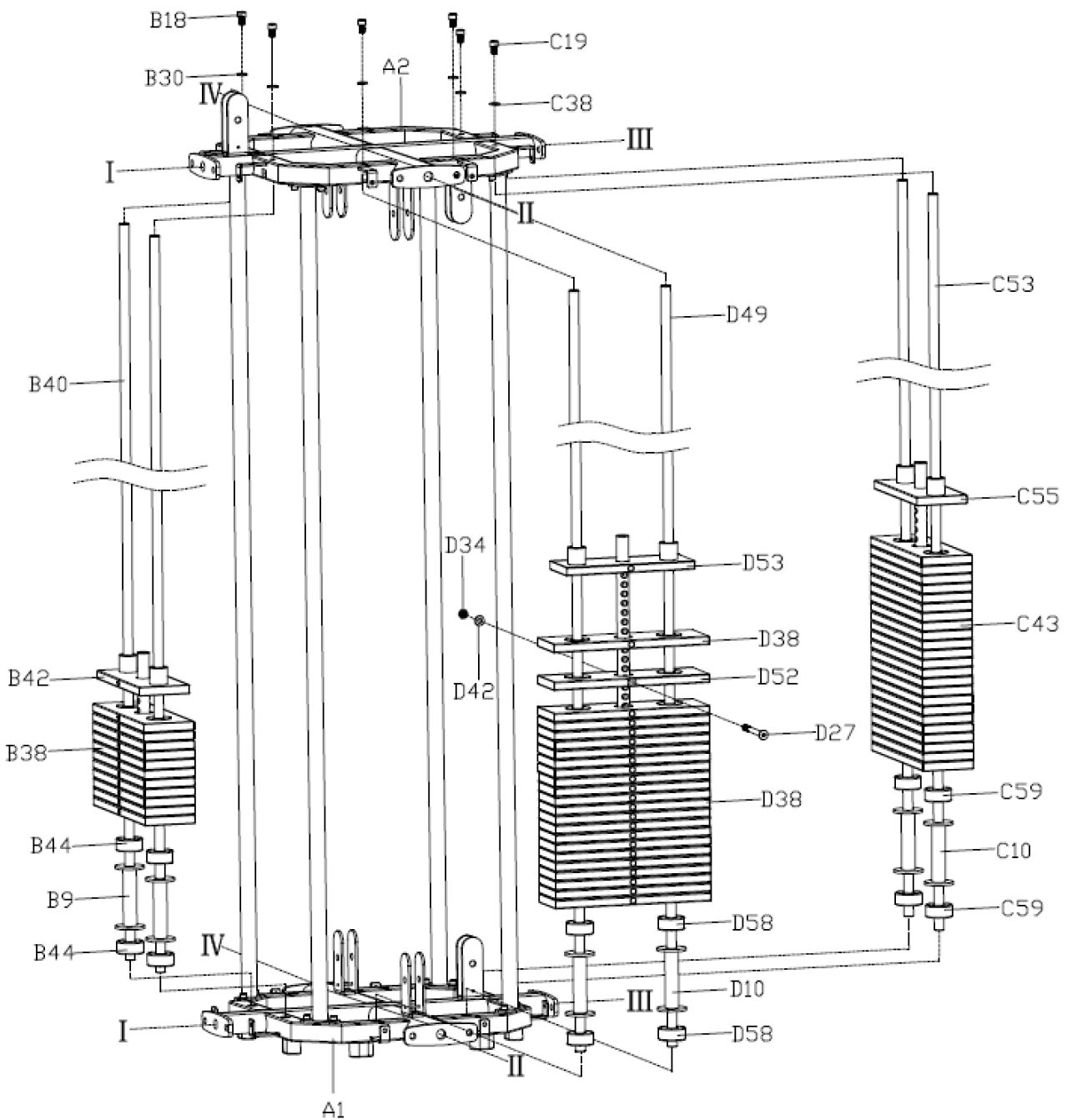



## Function A:

**Section E Weight block: NONE**

**Section F Weight block:** Attach Slide bar (F29) to bottom seat (A1), then put in follow parts in the right order: Crash pad (F42). Top tube (F7), Weight block (F28), Rod (F35) onto (F29). Then attach (F29) to Upper seat (A2) with Hexagon bolt (F16) and Flat washer (F24) .

**Section G Weight block:** Attach Slide bar (G49) to bottom seat (A1), then put in follow parts in the right order: Crash pad (G54). Top tube (G9), Weight block (G55), Rod (G52) onto (G49). Then attach (G49) to Upper seat (A2) with Hexagon bolt (G48) and Flat washer (G41) .

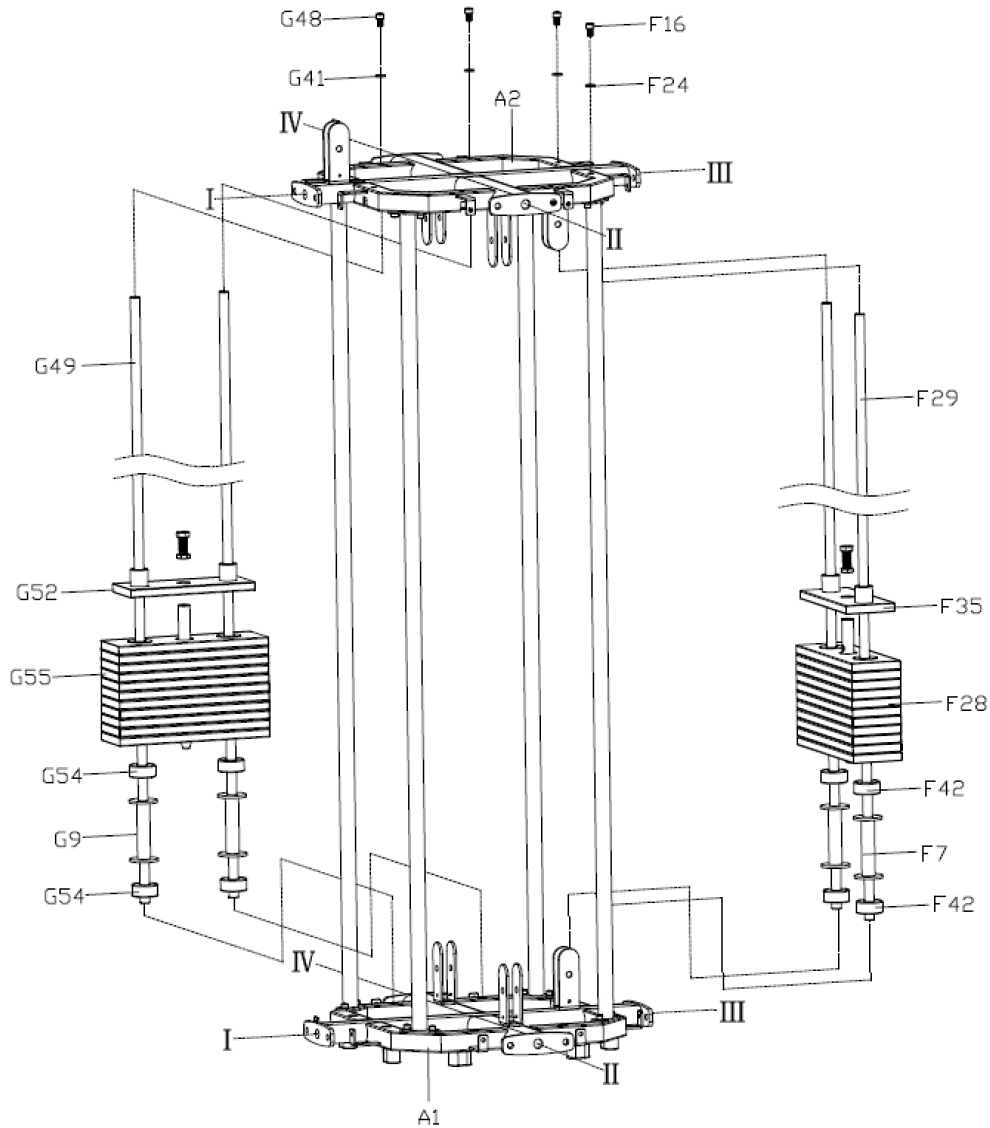

## Function A:

### Step 3 (NOTE: If choose function C; if not, pass this step)

1. Attach Connect rope (C73) to Pull rod (C55), as showing blow.
2. Attach Alloy sleeves (C42), Pulley (C58) to Upper seat (A2) with Hexagon bolt (C15), Flat Washer (C37) and Nylon nut (C28)
3. Attach Alloy sleeves (C42), Pulley (C58) to Bottom seat (A1) with Hexagon bolt (C15), Flat Washer (C37) and Nylon nut (C28)
4. Attach Magnetic bolt (C67) to Weight block (C43) and connect Magnetic bolt (C67) to Connect rope(C73)

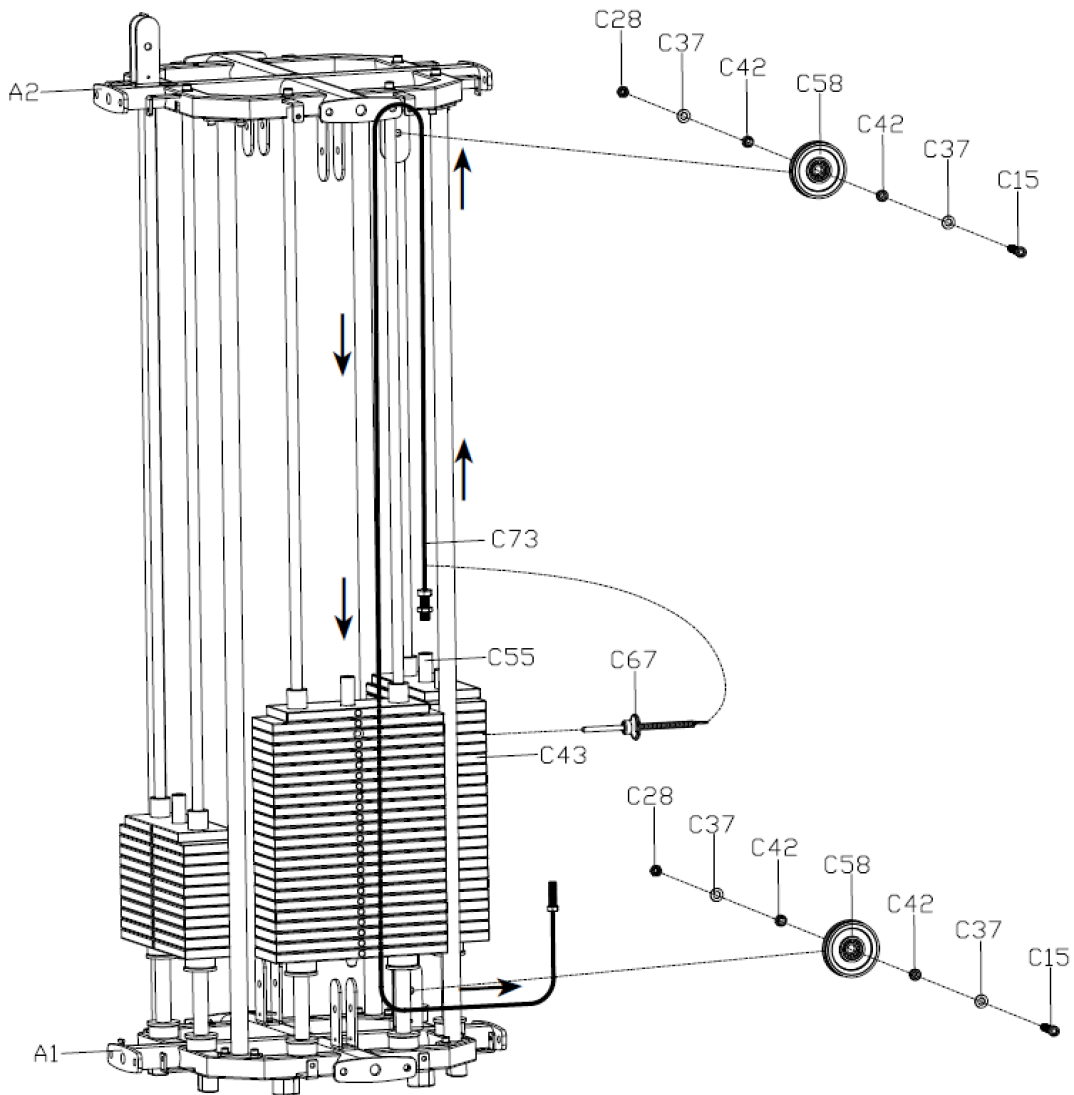

## Function A:

### Step 3 (NOTE: If choose function D; if not, pass this step)

1. Attach rope (D72) to Pull rod (D53), as showing blow.
2. Attach Alloy sleeves (D41), Pulley (D56) to Upper seat (A2) with Hexagon bolt (D14), Flat Washer (D43) and Nylon nut (D32)
3. Attach Alloy sleeves (D41), Pulley (D56) to Bottom seat (A1) with Hexagon bolt (D14), Flat Washer (D43) and Nylon nut (D32)
4. Attach Magnetic bolt (D68) to Weight block 1 (D68) and connect Magnetic bolt (D68) to Connect rope(D72)

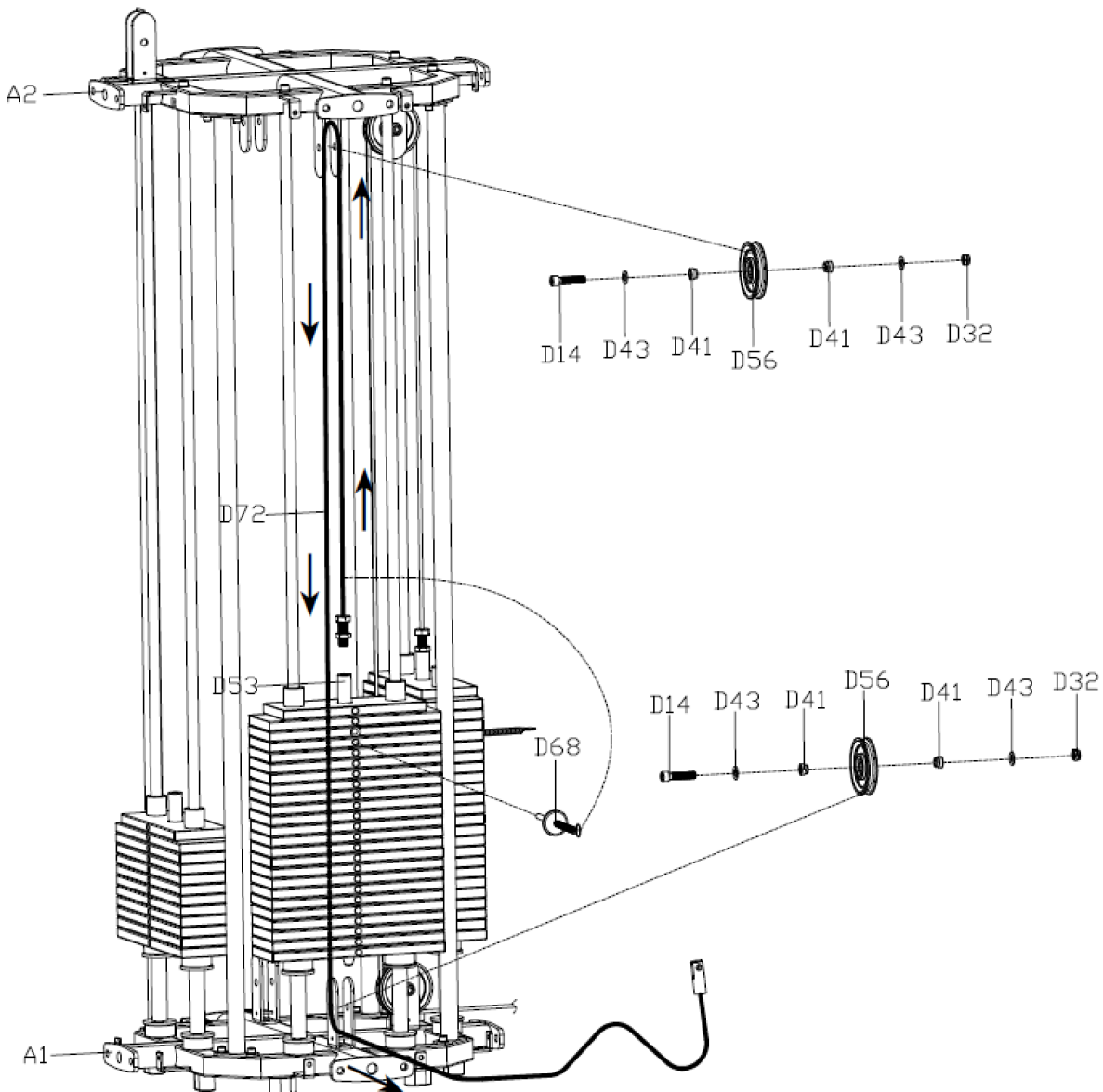

**Function A:**

**Step 3 (NOTE: If choose function F; if not, pass this step)**

1. Attach rope (F49) to Pull rod (F35), as showing blow.
2. Attach Alloy sleeves (F27), Pulley (F44) to Upper seat (A2) with Hexagon bolt (F12), Flat Washer (F23) and Nylon nut (F20)
3. Attach Alloy sleeves (F27), Pulley (F44) to Bottom seat (A1) with Hexagon bolt (F12), Flat Washer (F23) and Nylon nut (F20)
4. Attach Magnetic bolt (F51) to Weight block (F28) and connect Magnetic bolt (F51) to Connect rope(F49)

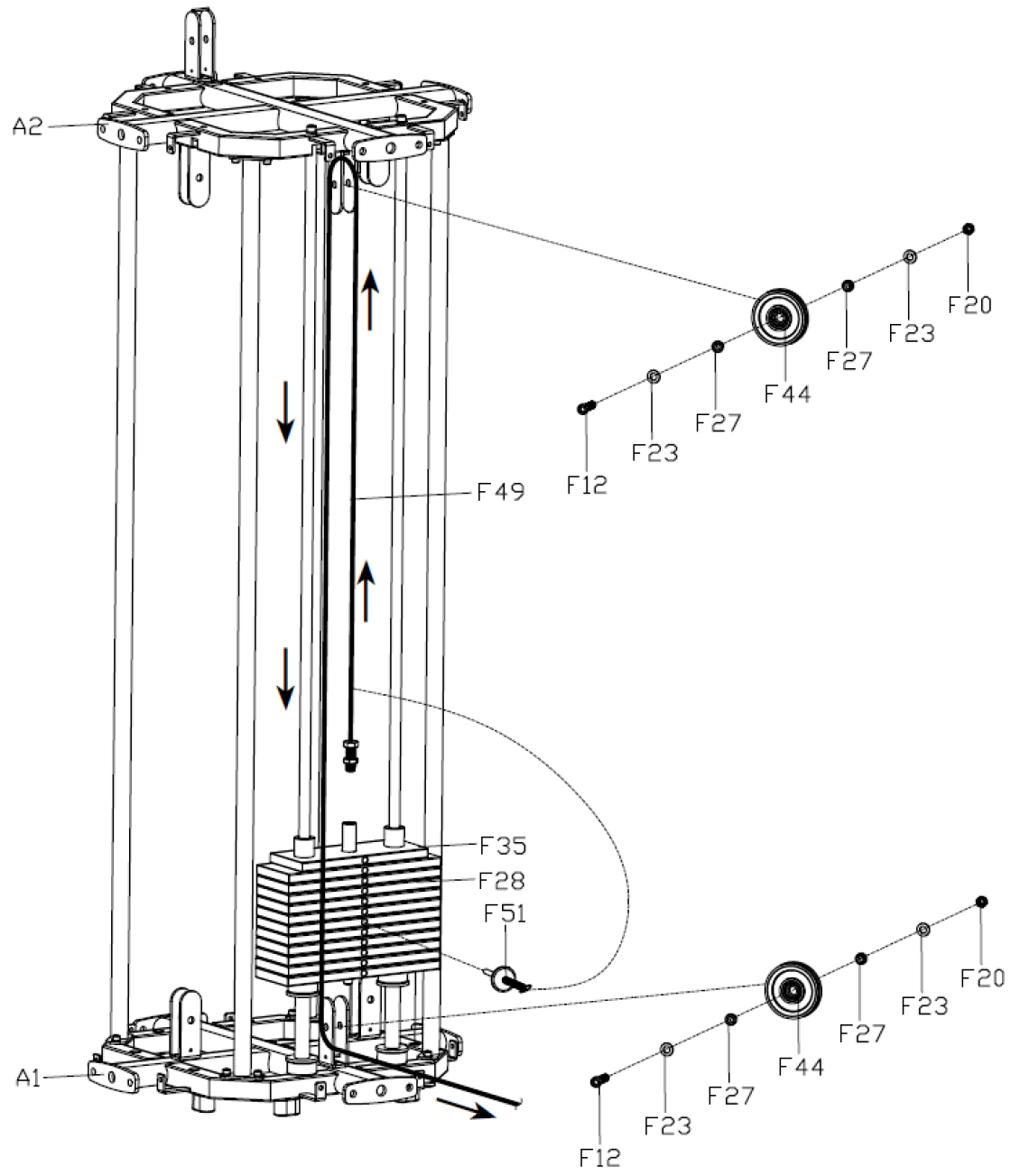

## Function A:

### Step 3 (NOTE: If choose function G; if not, pass this step)

1. Attach rope (G47) to Pull rod (G52), as showing blow.
2. Attach Alloy sleeves (G38), Pulley (G37) to Upper seat (A2) with Hexagon bolt (G32), Flat Washer (G33) and Nylon nut (G35)
3. Attach Alloy sleeves (G38), Pulley (G37) to Bottom seat (A1) with Hexagon bolt (G32), Flat Washer (G33) and Nylon nut (G35)
4. Attach Magnetic bolt (G50) to Weight block (G55) and connect Magnetic bolt (G50) to Connect rope(G47)

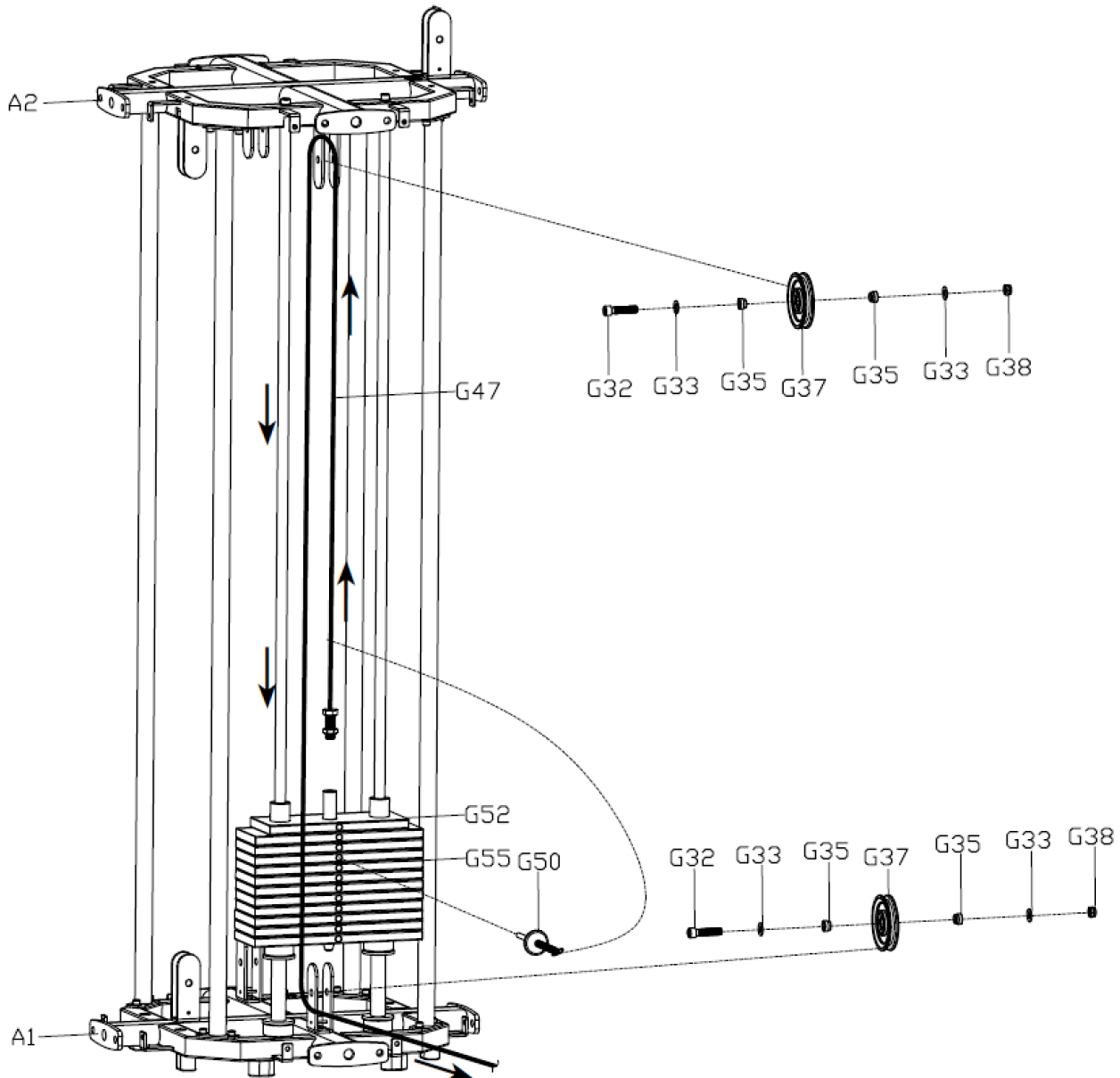

**Function A:**

**Step 4 (NOTE: This step does not differentiate functions; the installations are all the same.)**

1. Attach Cover (A3) to Upper and Bottom seat (A1 and A2) with Hexagon bolt (A6), Flat Washer (A9), make Hexagon bolt (A6) unlocked temporarily.
2. Attach Cover (A4) to Upper and Bottom seat (A1 and A2) with Hexagon bolt (A6), Flat Washer (A9), make Hexagon bolt (A6) unlocked temporarily.

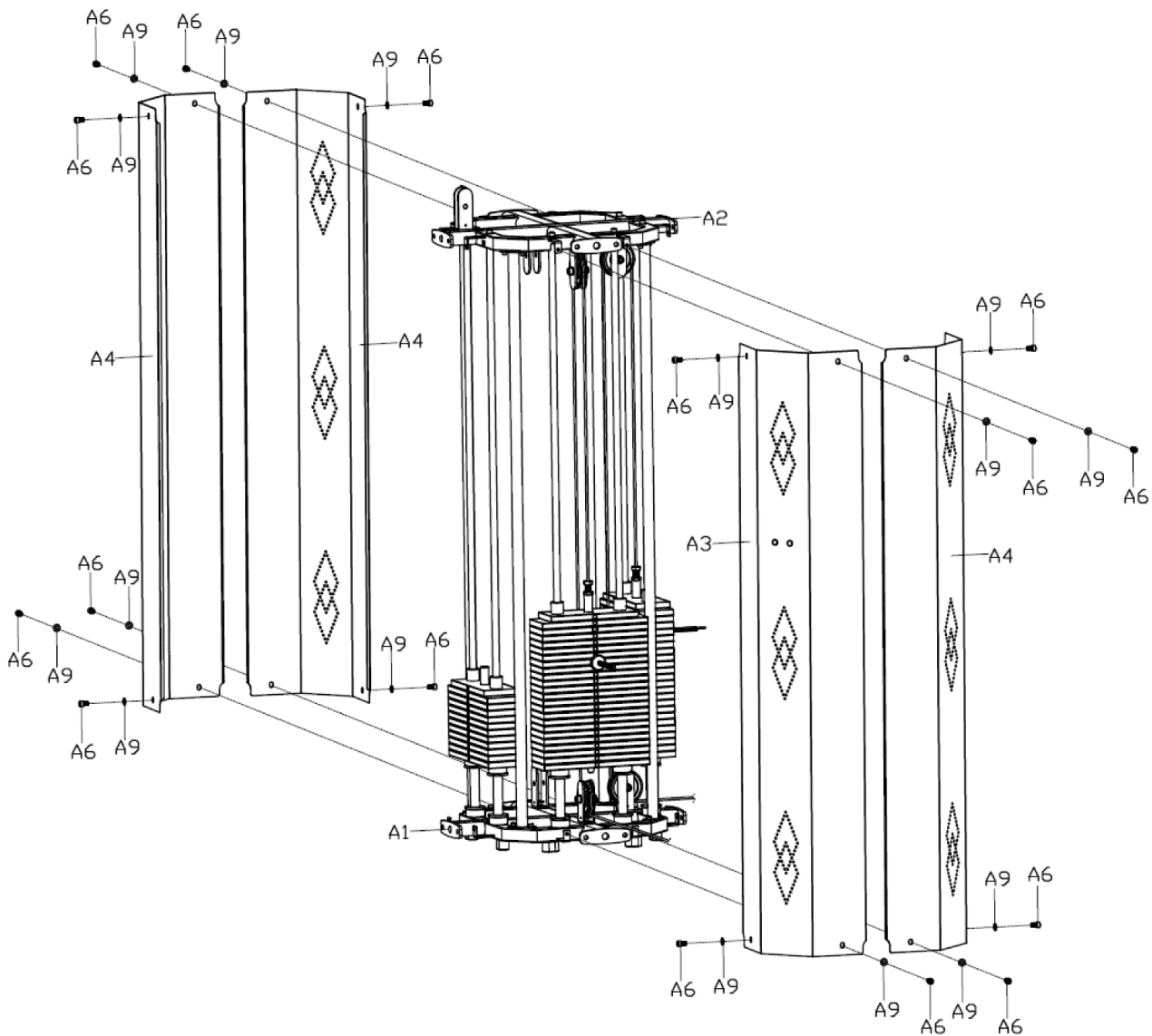

## Function A:

**Step 5 (NOTE: This step does not differentiate functions; the installations are all the same.)**

1. Attach Shelf tube (A5) to Cover (A3)
2. Attach Water bottle (A12) to Shelf tube (A5) with cross screw (A8)

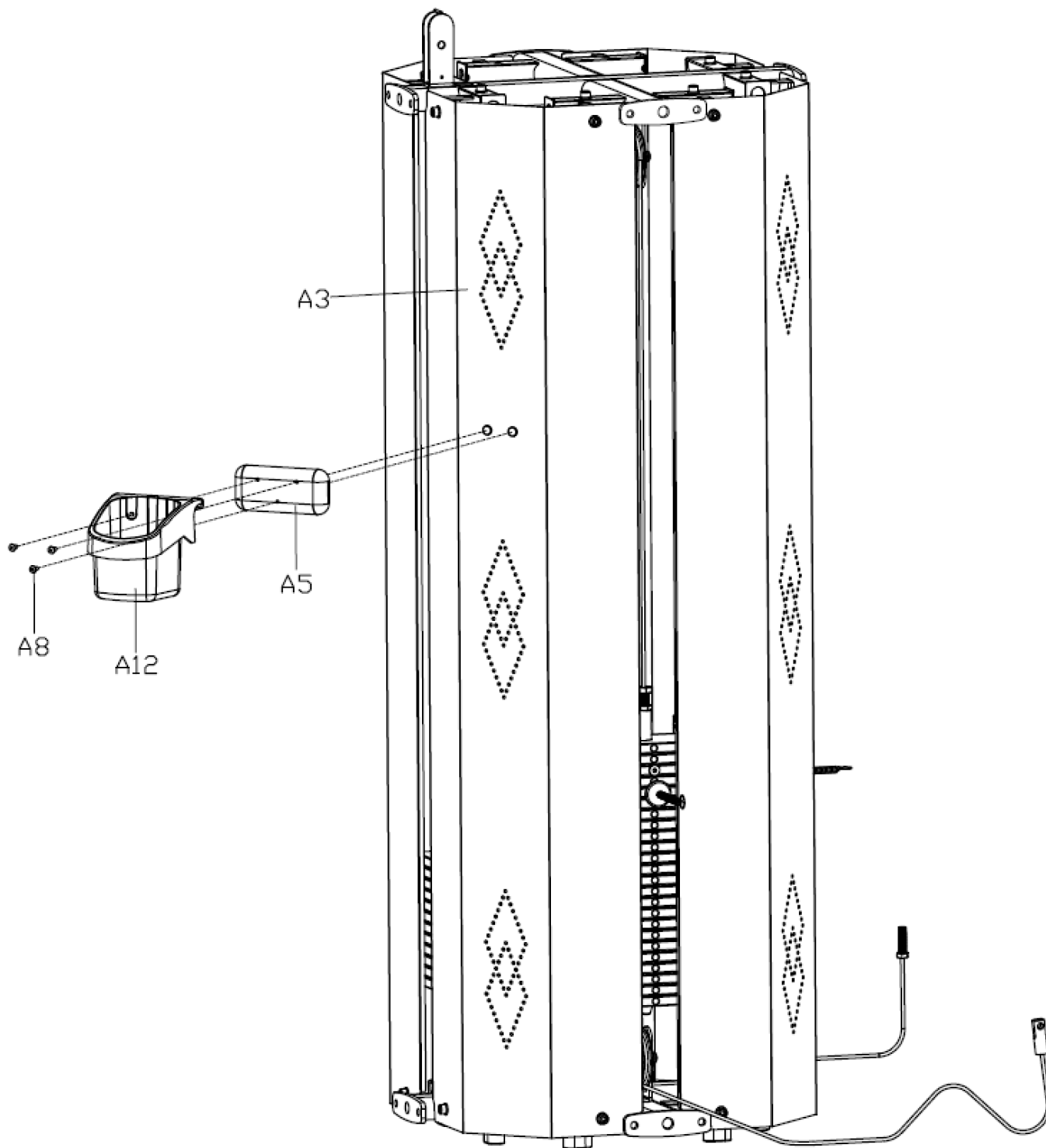

**Function B:**

**Step 1:**

1. Attach Main base frame (B2) to Main Seat frame (B1)
2. Attach Foot pedal tube(B11) to Main Seat frame (B1)
3. Attach Cant Beam frame (B3) to Main base frame (B2) with Square bolt (B19), Connect plate(B8), Flat washer (B30) and Nylon nut(B25)

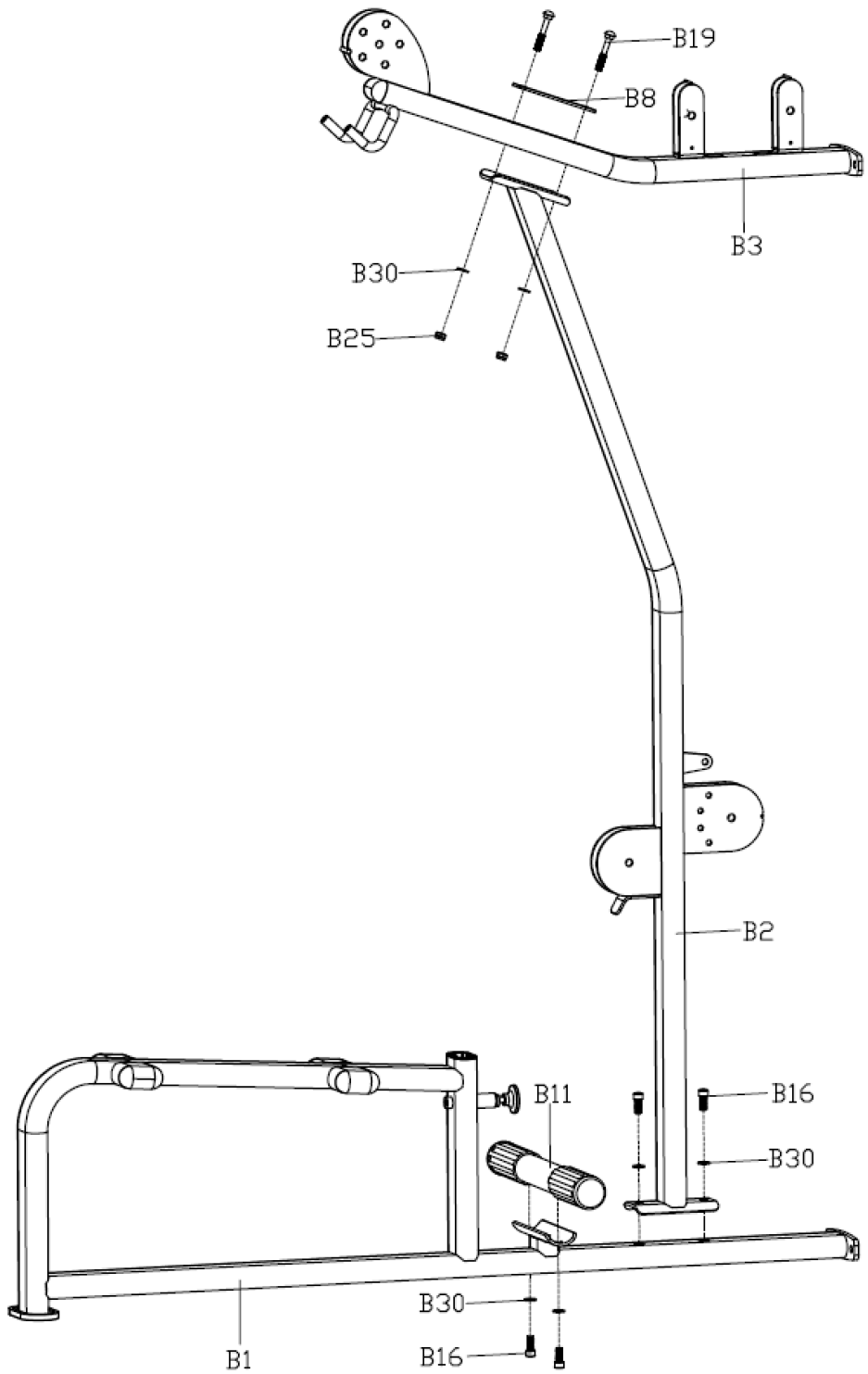



**Function B:**

**Step 2:**

1. Attach Foam outer cap (B51), Foam (B49) and Foam inner cap (B52) to Leg Adjusting frame (B4) with Hexagon bolt (B22), Flat Washer (B31).
2. Back-out Hexagon bolt (B16), take out Bolt (B41). Attach Leg Adjusting frame (B4) to Main Seat frame (B1), then tighten Hexagon bolt (B16) after.
3. Attach Seat (B57) to Main Seat frame (B1) with Hexagon bolt (B21), Flat Washer (B32).

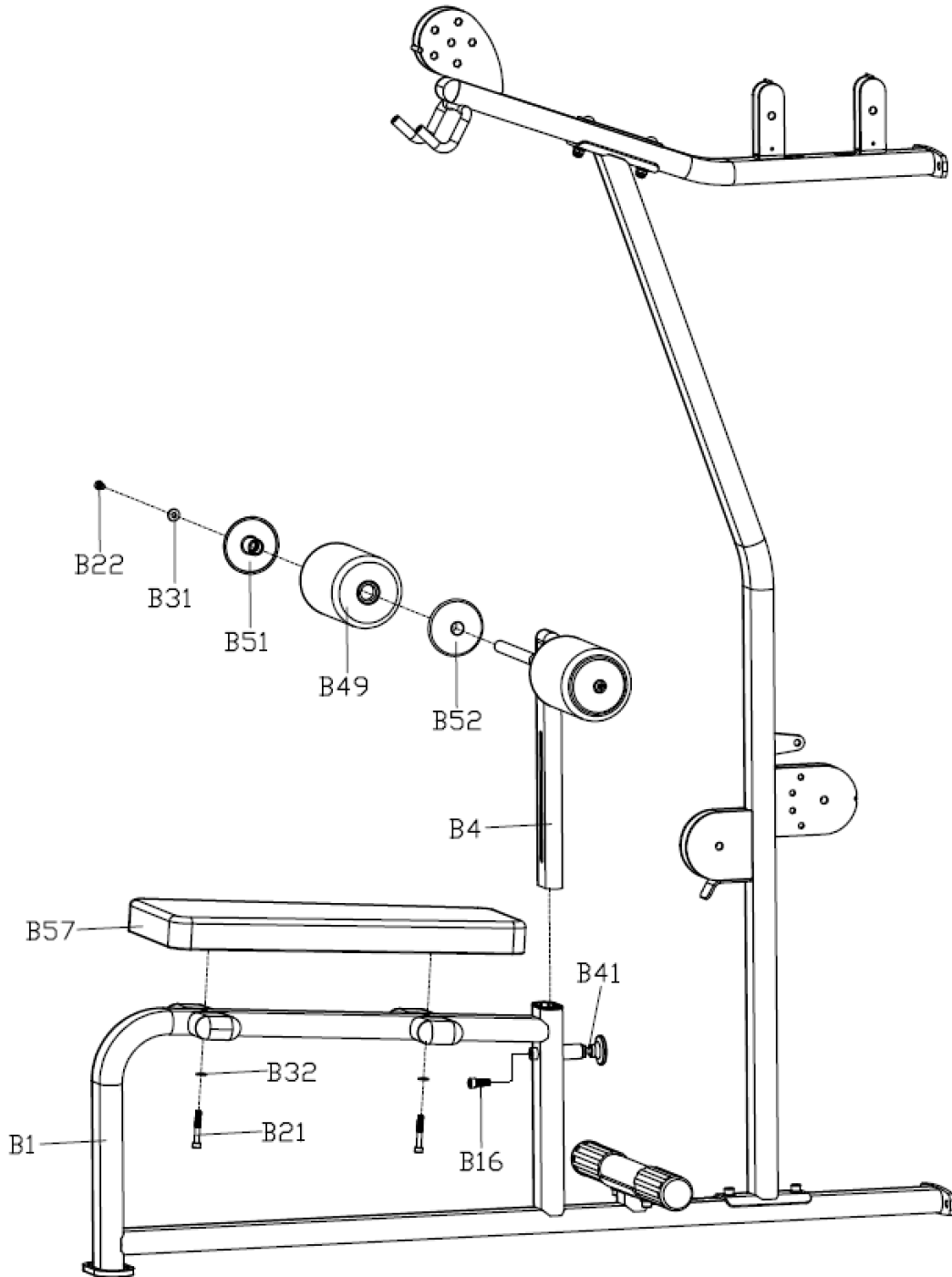

## Function B:

### Step 3:

1. Attach Main Seat frame (B1) to Bottom seat (A1) with Hexagon bolt (B14), Flat Washer (B29) and Nylon nut (B23)
2. Attach Cant Beam frame (B3) to Upper seat (A2) with Hexagon bolt (B14), Flat Washer (B29) and Nylon nut (B23)

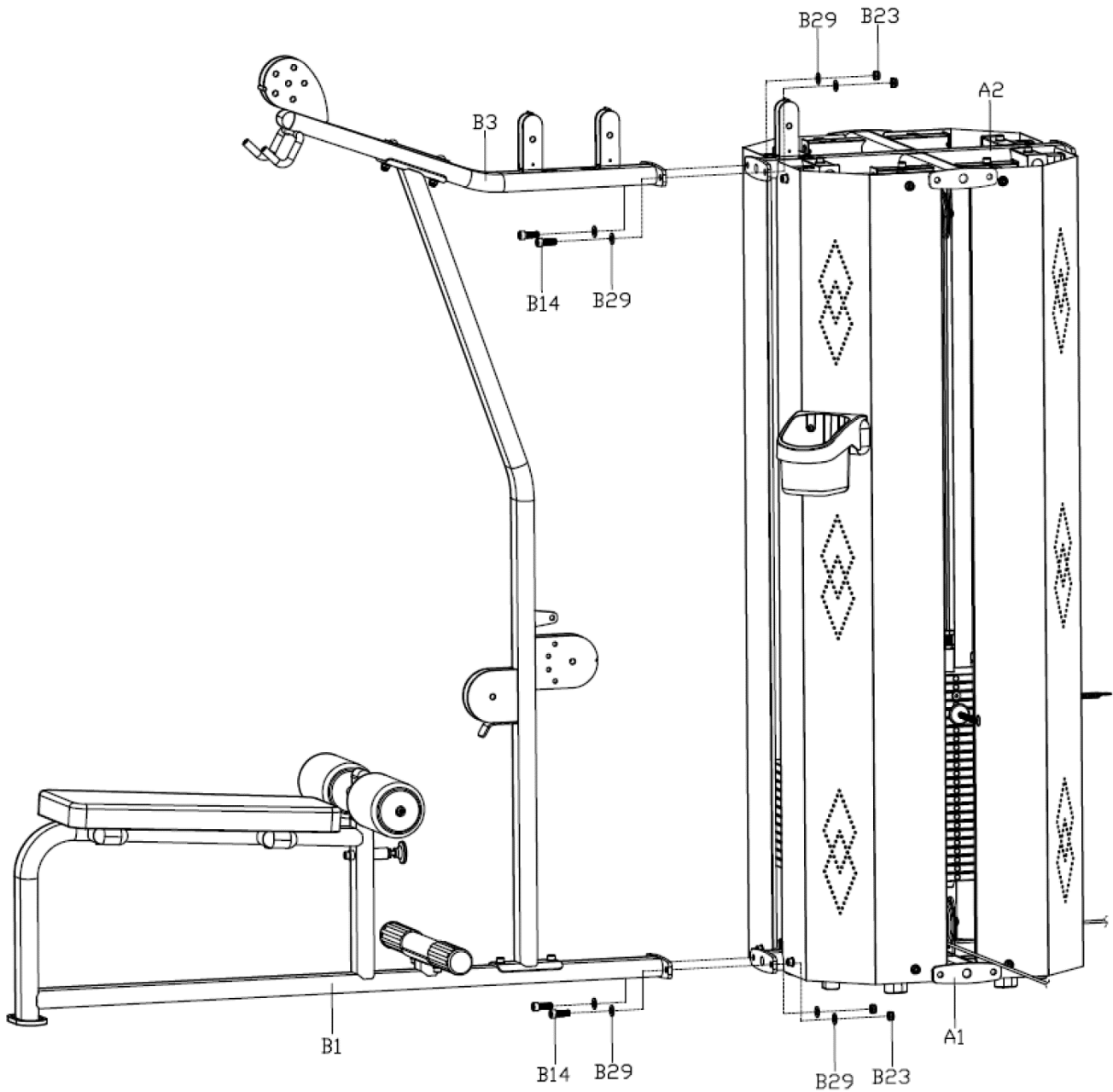

## Function B:

### Step 4:

1. Install Rope (B61) as showing blow
2. Attach Alloy Sleeve (B37) and Pulley (B43) to Cant Beam frame (B3) with Hexagon bolt (B13), Flat Washer (B29) and Nylon nut (B23)
3. Attach Pulley cover (B46), Alloy Sleeve (B37) and Pulley (B43) to Cant Beam frame (B3) with Hexagon bolt (B12), Flat Washer (B29) and High cap nut (B24)
4. Attach Pulley cover (B46), Alloy Sleeve (B37) and Pulley (B43) to U Shape clevis (B7) with Hexagon bolt (B12), Flat Washer (B29) and High cap nut (B24)
5. Attach Pulley cover (B46), Alloy Sleeve (B37) and Pulley (B43) to Upper seat (A2) with Hexagon bolt (B12), Flat Washer (B29) and High cap nut (B24)
6. Attach Rope (B61) to Pull rod (B42) and attach magnetic bolt (B56) into Rope (B61), then plug magnetic bolt (B56) into Weight block (B38).

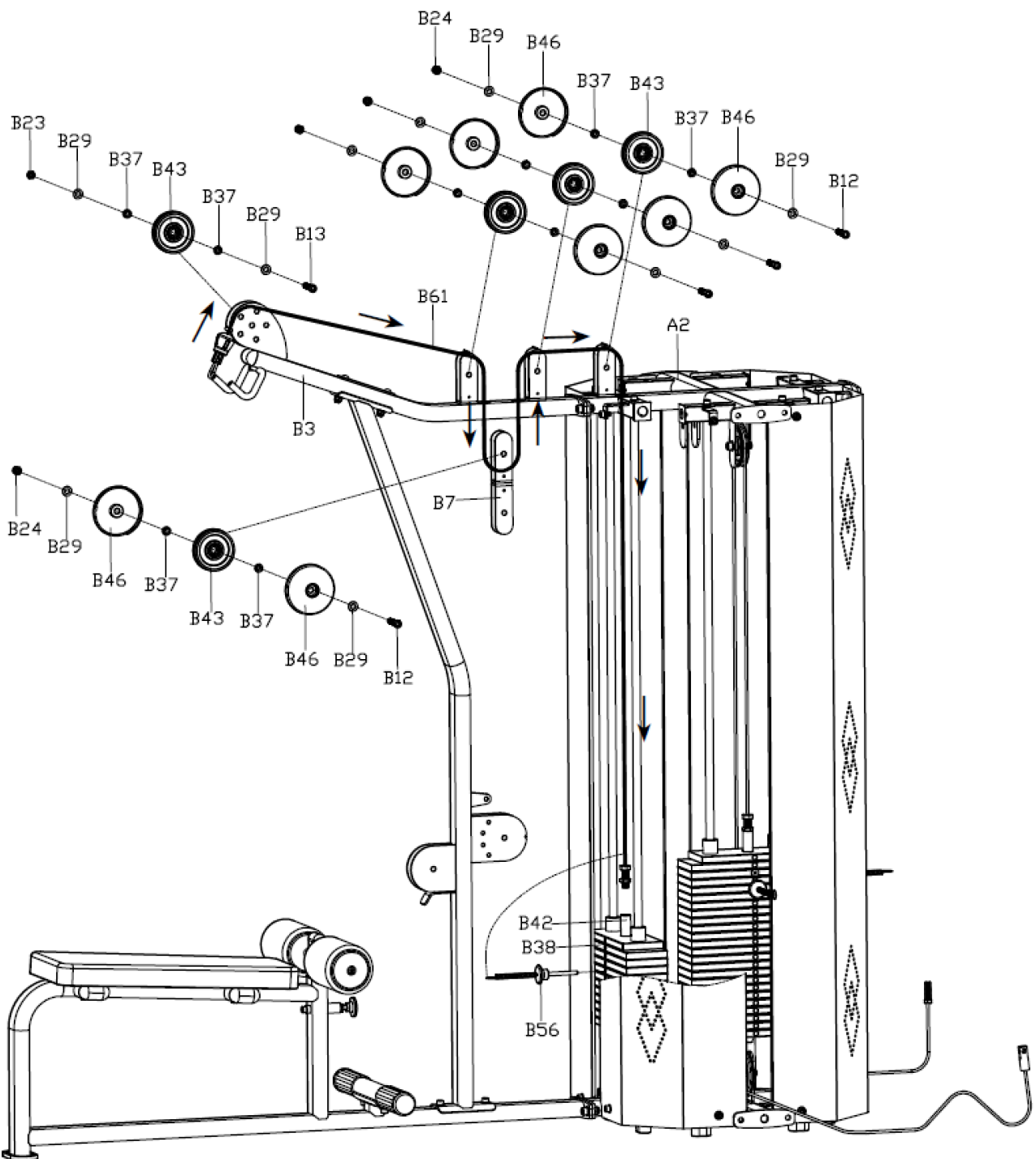

## Function B:

### Step 5:

1. Install Rope (B62) as showing blow, then attach (B62) to Main base frame (B2) with Hexagon bolt (B15), Flat Washer (B30) and Nylon nut (B25)
2. Attach Alloy Sleeve (B37) and Pulley (B43) to Main base frame (B2) with Hexagon bolt (B13), Flat Washer (B29) and Nylon nut (B23)
3. Attach Pulley cover (B46), Alloy Sleeve (B37) and Pulley (B43) to U Shape clevis (B7) with Hexagon bolt (B12), Flat Washer (B29) and High cap nut (B24)

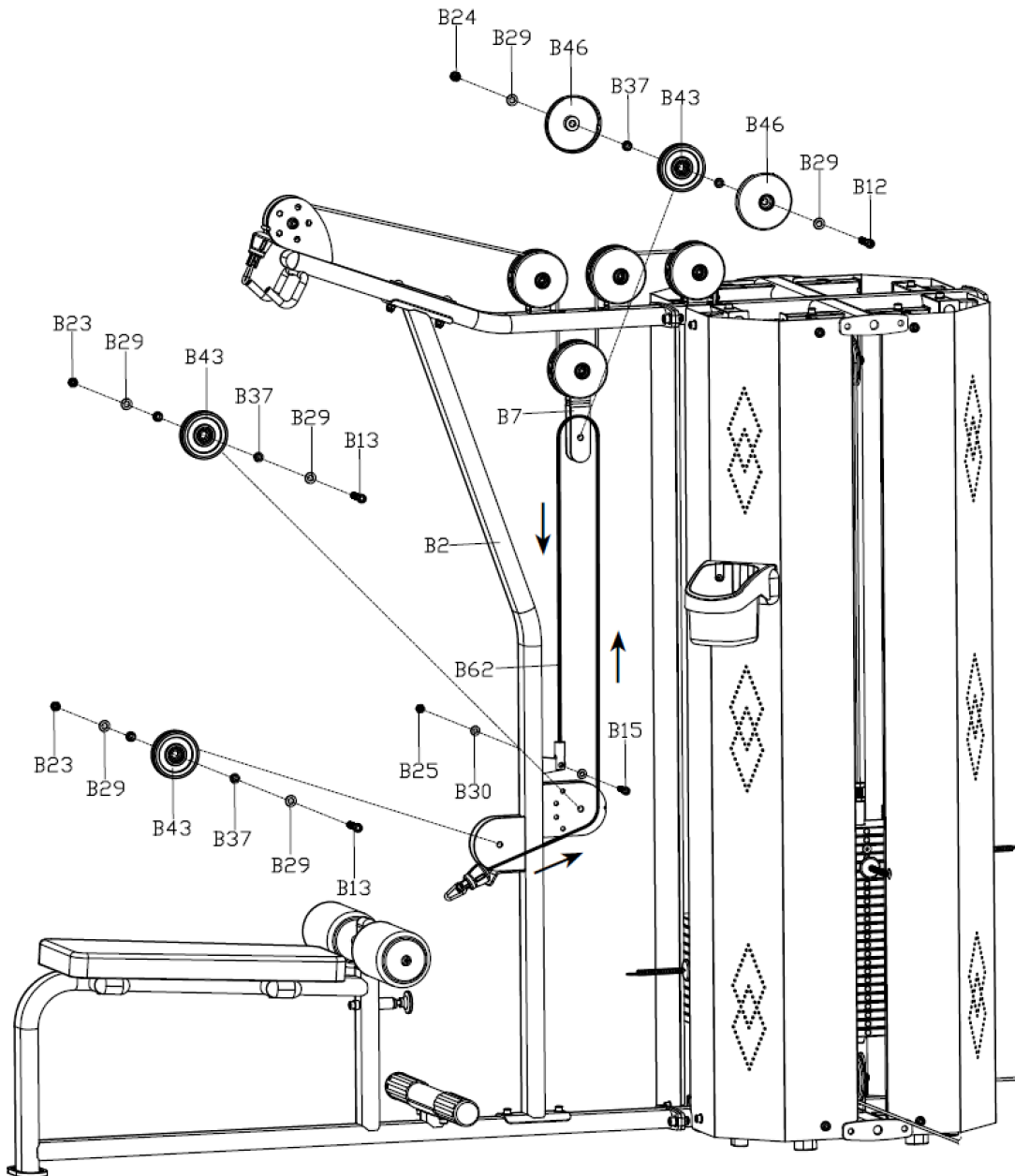

## Function B:

### Step 6:

1. Attach Long Handle (B5) to High pull down rope (B61) with Hook (B35)
2. Attach Short Handle (B6) to Low row rope (B62) with Hook (B35)

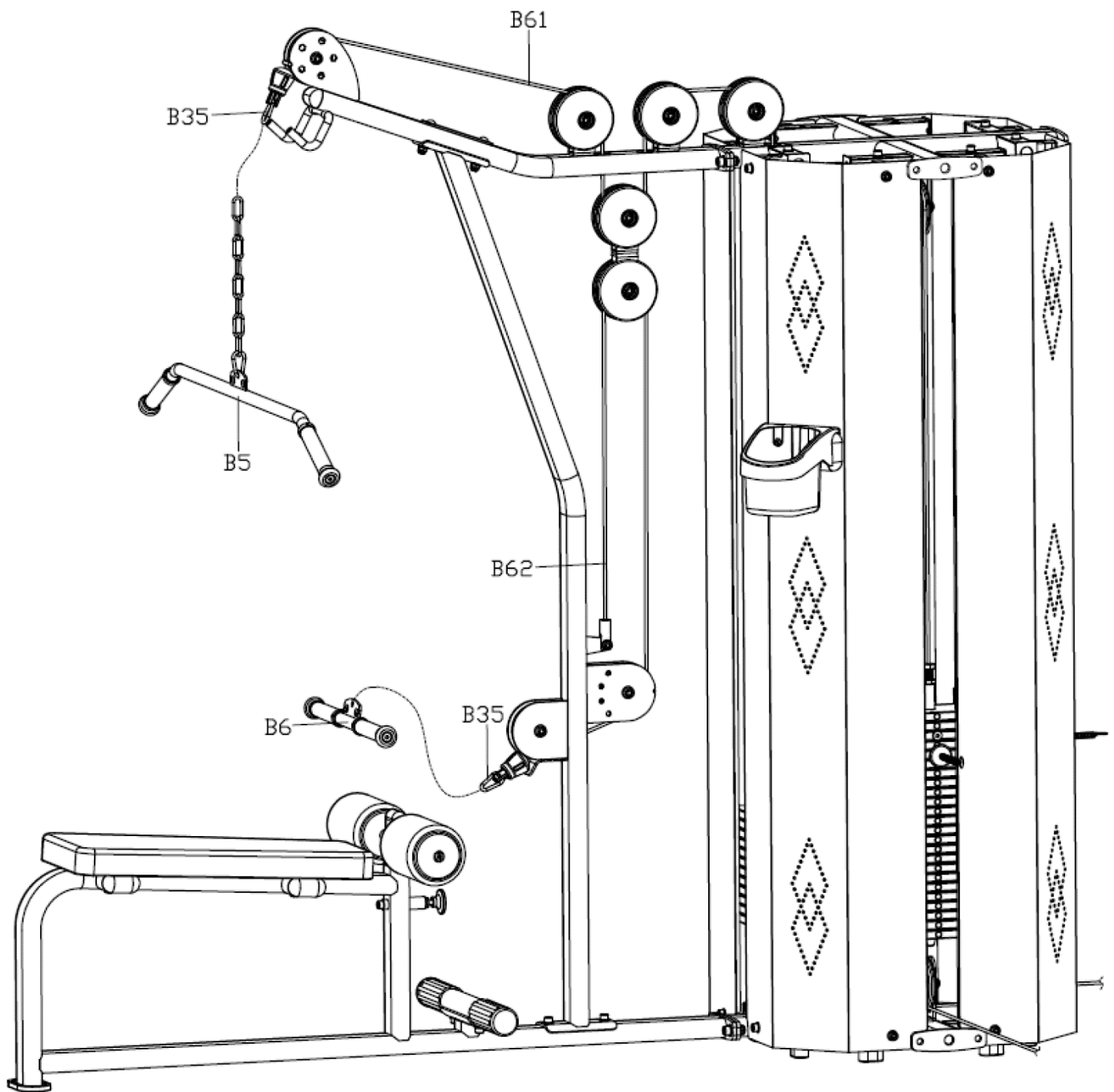

## Function C:

### Step 1:

1. Attach Seat (C56) to Seat post (C8) with Hexagon bolt (C21), Flat Washer (C39)
2. Attach Backrest (B57) to Backrest post (C7) with Hexagon bolt (C21), Flat Washer (C39)
3. Back-out Hexagon bolt (C17), take out Bolt (C54). Attach Seat post (C8) to Upper frame (C1), then tighten Hexagon bolt (C17) after.
4. Back-out Hexagon bolt (C17), take out Bolt (C54). Attach Backrest post (C7) to Upper frame (C1), then tighten Hexagon bolt (C17) after.

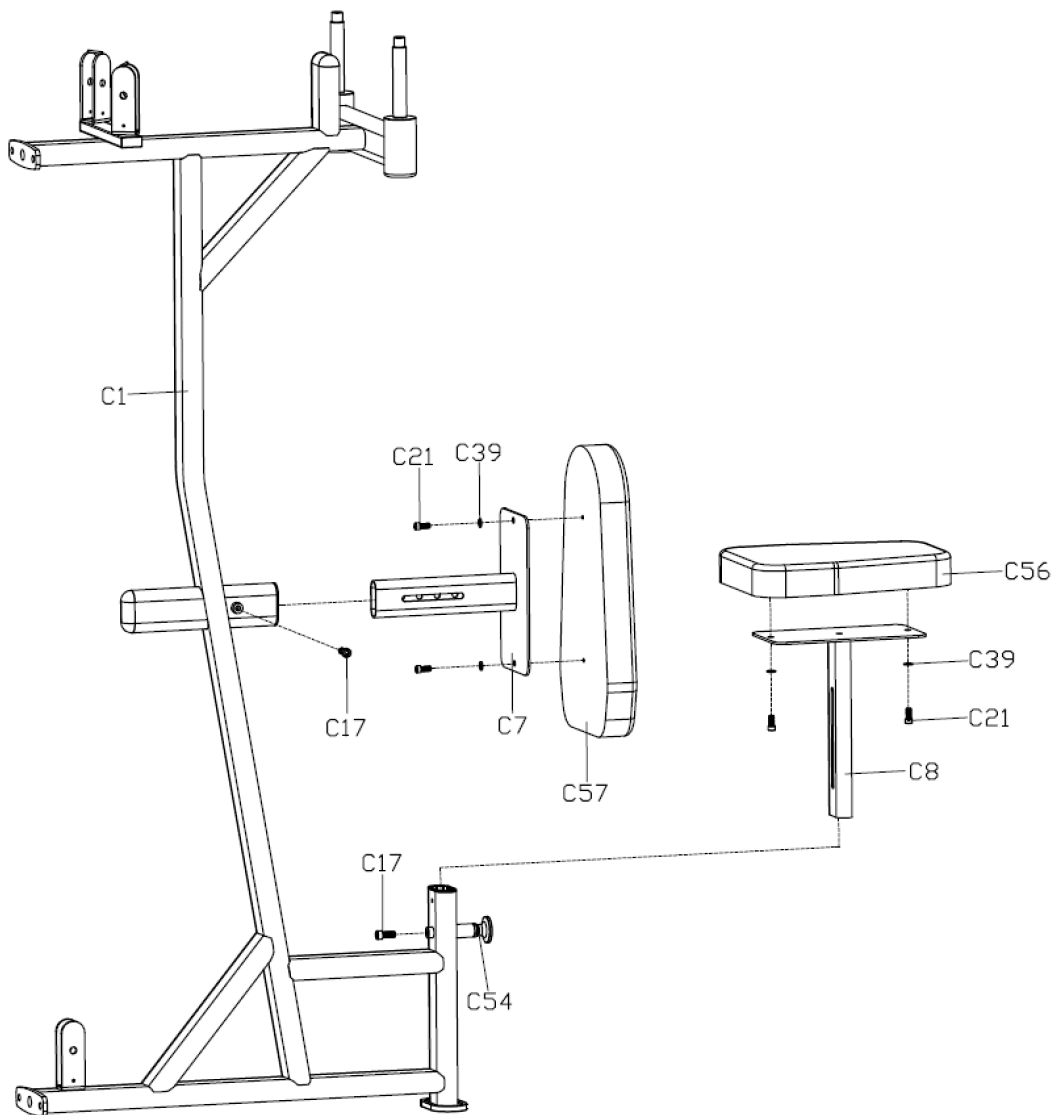

## Function C:

### Step 2:

1. Attach Upper fly arm (C4), Right Guide cam (C2), Left Guide cam (C3) to Upper frame (C1) in the right order, and screw on Collar block (C12) with Hexagon screw (C24) on Upper frame (C1). **(NOTE: Pull up Bolt (C44) and match the hole site on Right Guide cam (C2) and Left Guide cam (C3) when install Upper fly arm (C4))**
2. Attach Left Butterfly arm (C5) and Right Butterfly arm (C6) to Upper fly arm (C4) with Hexagon screw (C18), End cap(C46), minor axis (C45).

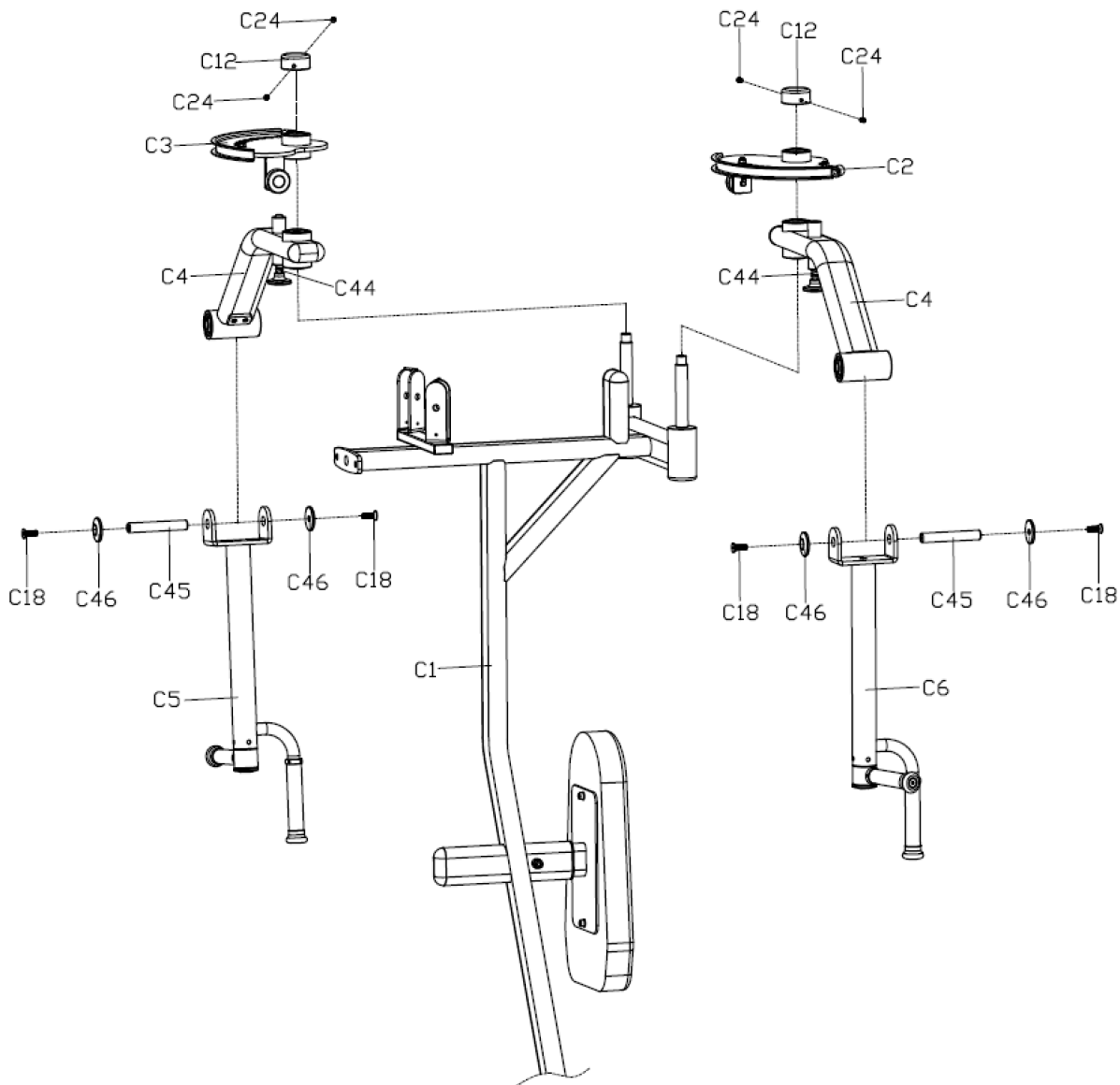

## Function C:

### Step 3:

1. Attach Rope (C72) to Left Guide cam (C3) with Rope fix sleeve (C27), then install the other side of (C72) as showing blow. Attach Rope (C72) to Right Guide cam (C2) with Rope fix sleeve (C27) after.
2. Attach pulley cover (C63), Alloy Sleeve (C42) and Pulley(C58) to Upper frame (C1) with Hexagon bolt (C14), Flat washer (C37), high cap nut (C29).
3. Attach pulley cover (C63), Alloy Sleeve (C42) and Pulley(C58) to Pulley bracket (C9) with Hexagon bolt (C14), Flat washer (C37), high cap nut (C29).

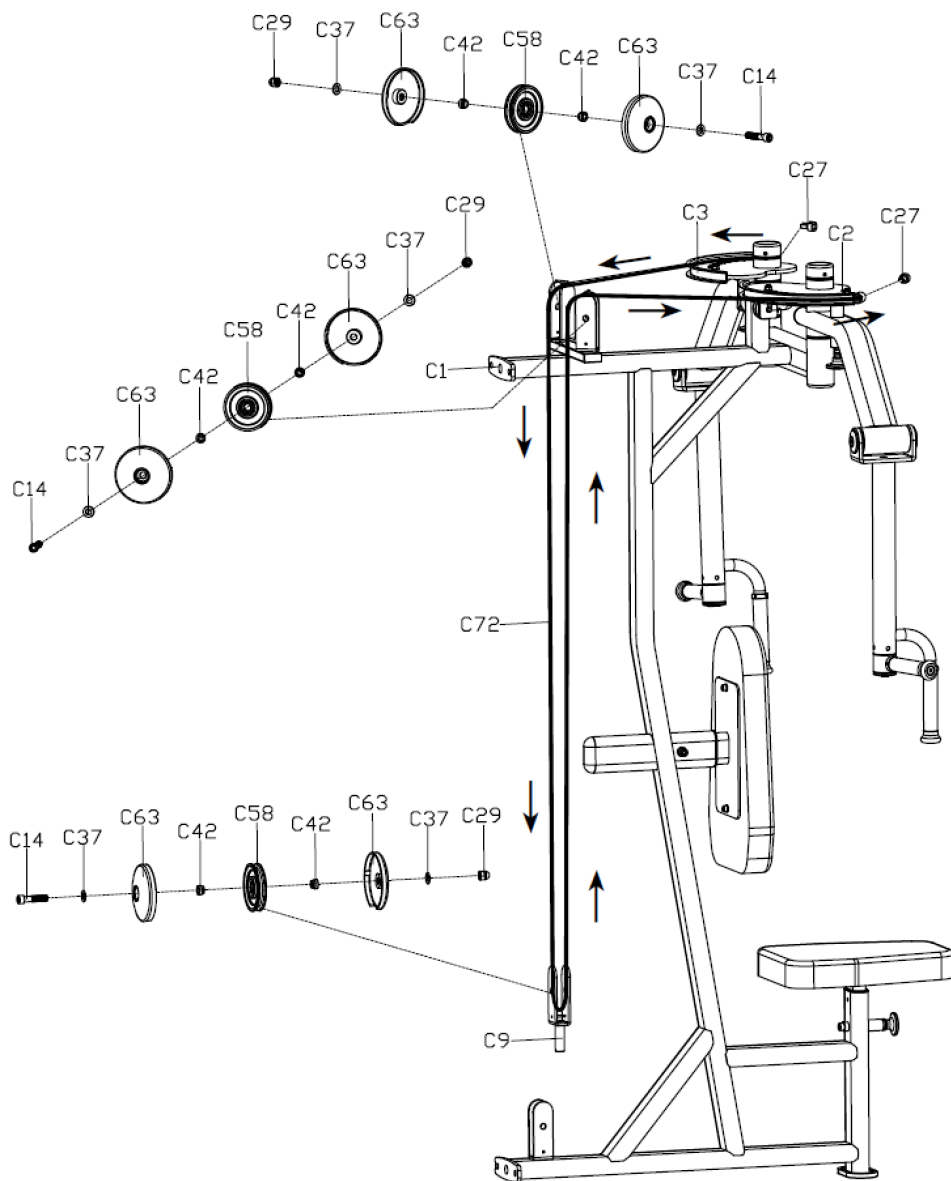



## Function C:

### Step 4:

1. Attach Upper frame (C1) to Bottom seat (A1) with Hexagon bolt (C16), Flat washer (C37), Nylon nut (C28).
2. Attach Upper frame (C1) to Upper seat (A2) with Hexagon bolt (C16), Flat washer (C37), Nylon nut (C28).
3. Install Rope (C73) as showing blow. Attach Rope (C73) to Pulley bracket (C9), tighten Flange nut (C32) after.
4. Attach pulley cover (C63), Alloy Sleeve (C42) and Pulley(C58) to Upper frame (C1) with Hexagon bolt (C14), Flat washer (C37), high cap nut (C29).

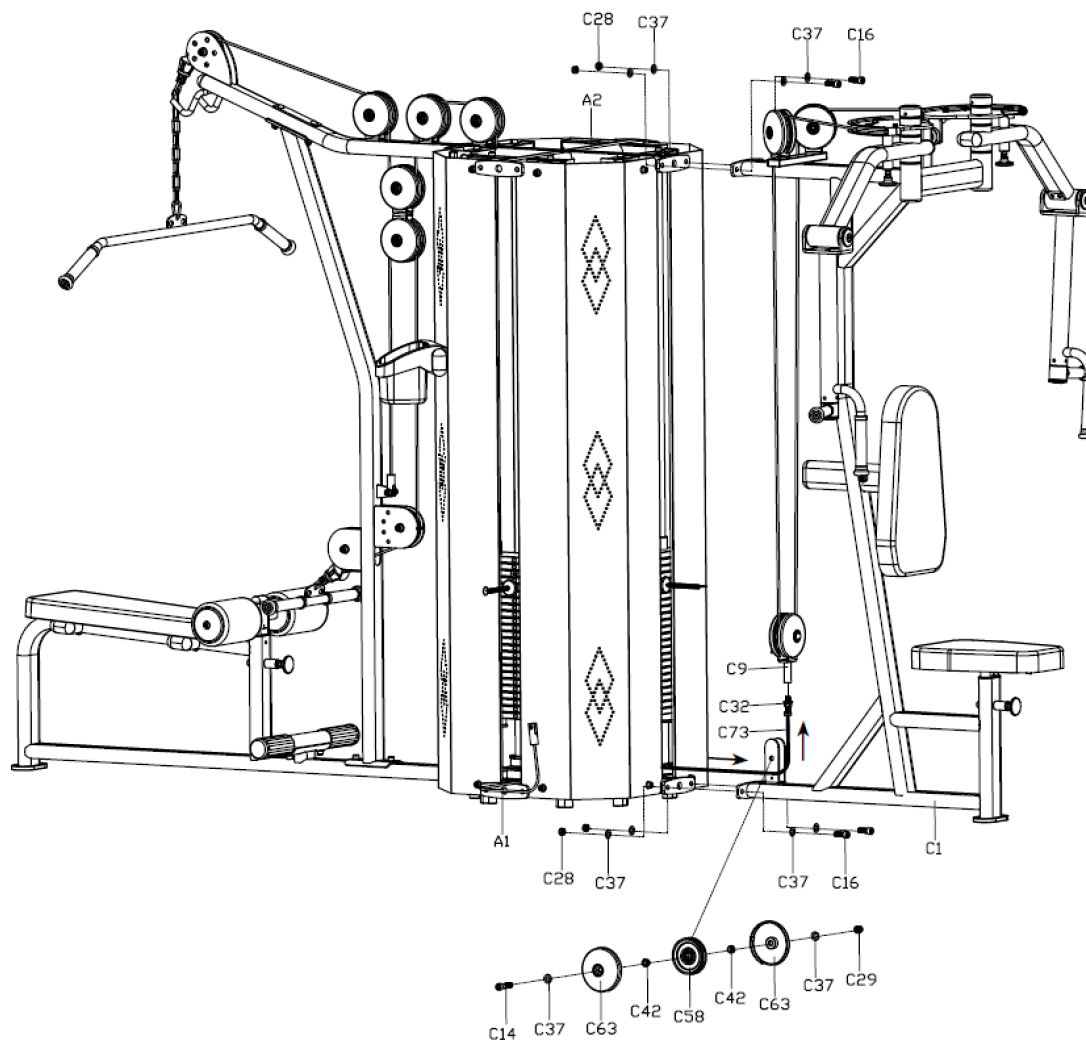

## Function D:

### Step 1:

1. Attach Connect tube (D1) to Seat tube (D2) with Hexagon bolt (D17), Flat washer (D43), Nylon nut (D32).
2. Attach Front base Frame (D3) to Seat tube (D2) with Hexagon bolt (D19), Flat washer (D42), Nylon nut (D34).

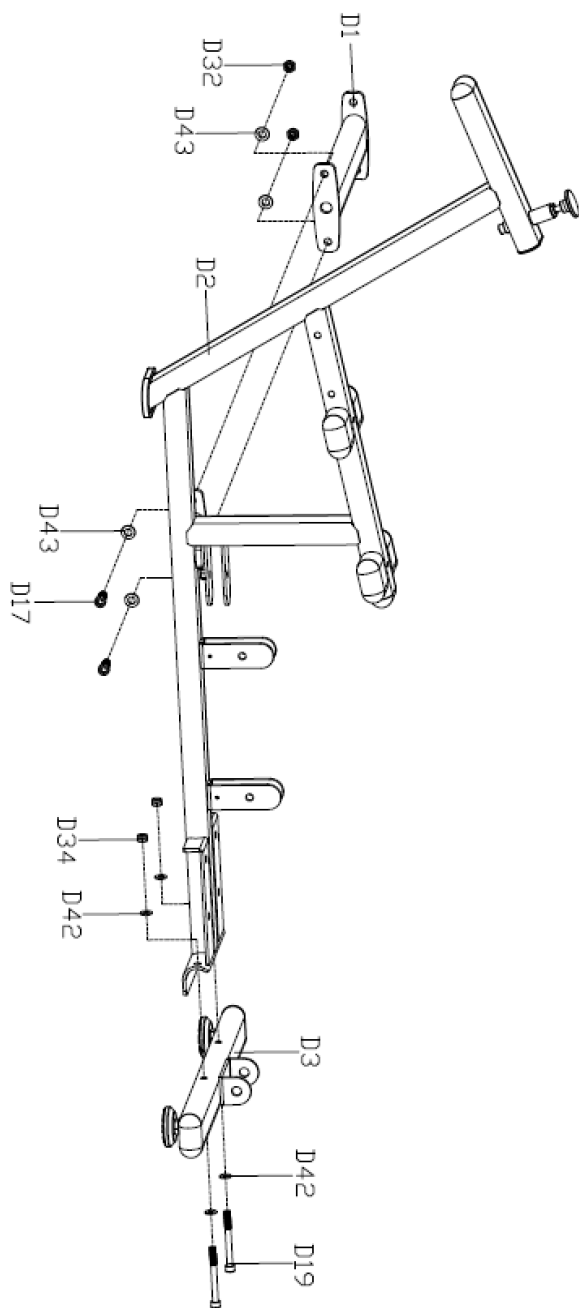

## Function D:

### Step 2:

1. Take off the screw on Bearing (D31), Attach Bearing (D31) to both side of connecting tube (D5), then attach (D31) on Seat tube (D2) with Hexagon bolt (D16), Flat washer (D43), Nylon nut (D32). Tighten the screw after.
2. Attach Front Connecting tube (D4) to Front base Frame (D3) with Hexagon bolt (D19), Flat washer (D43), Nylon nut (D32).

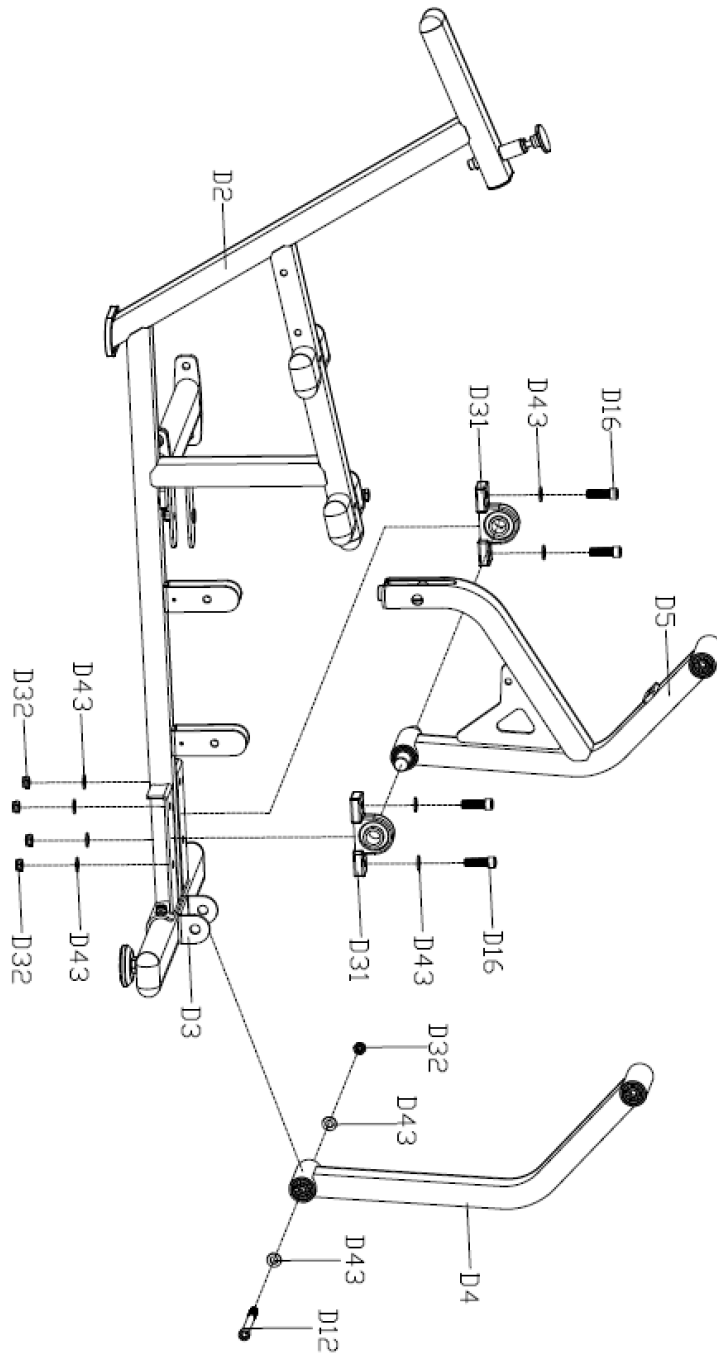

**Function D:**

**Step 3:**

1. Attach Pedal Connecting tube (D11) to Front Connecting tube (D4) and Rear Connecting tube (D5) with Hexagon bolt (D12), Flat washer (D43), Nylon nut (D32).
2. Attach Foot pedal (D6) to Pedal Connecting tube (D11) with Hexagon bolt (D20), Flat washer (D42), Nylon nut (D34).

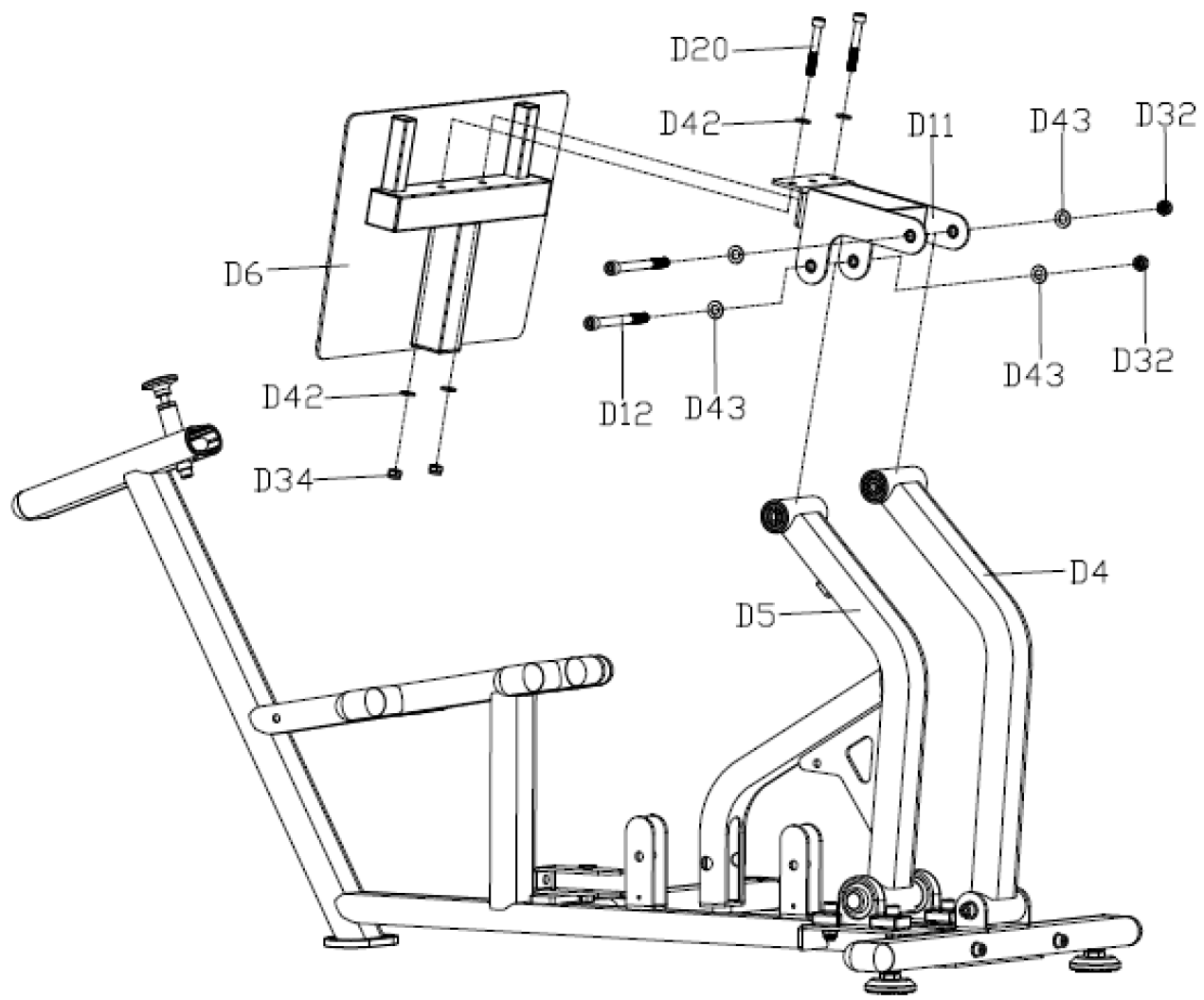

## Function D:

### Step 4:

1. Attach Right handle tube (D7) and Left handle tube (D8) to Seat tube (D2) with Hexagon bolt (D18), Flat washer (D42), Nylon nut (D34).

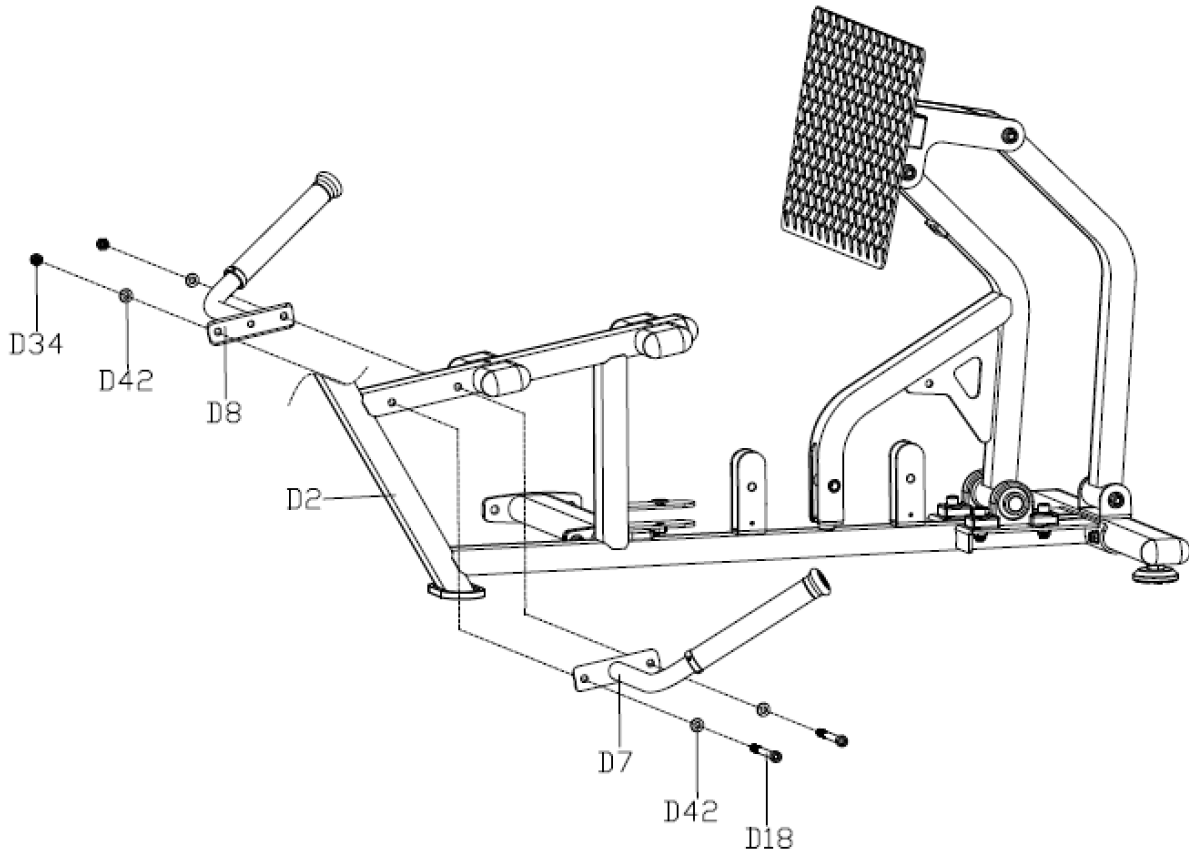

## Function D:

### Step 5:

1. Attach Seat (D54) to Seat tube (D2) with Hexagon bolt (D24), Flat washer (D45).
2. Attach Backrest (D55) to Backrest tube (D9) with Hexagon bolt (D25), Flat washer (D45)
3. Back-out Hexagon bolt (D22), take out Bolt (D51). Attach Backrest tube (D9) to Seat tube (D2), then tighten Hexagon bolt (D22) after.

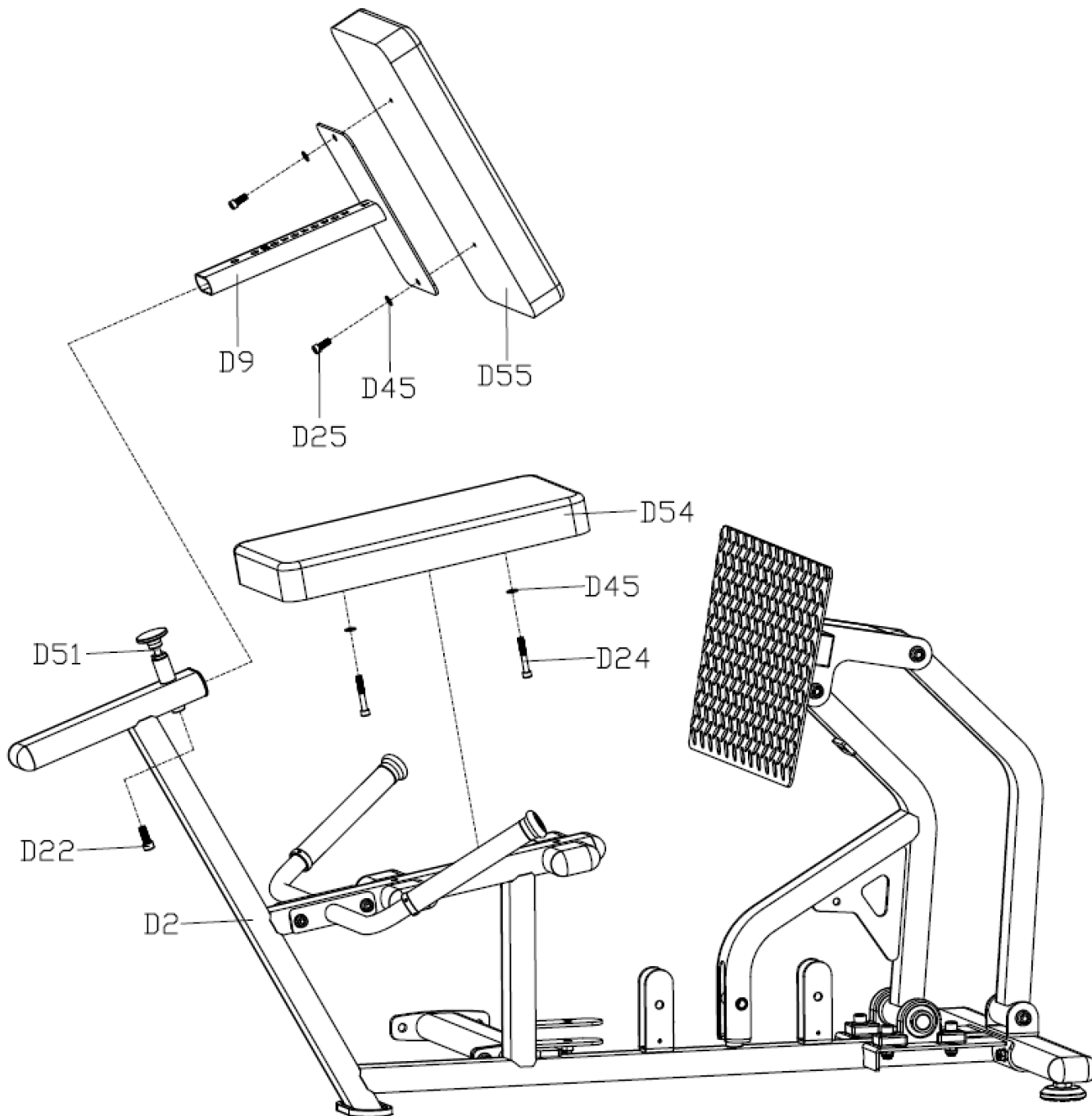

## Function D:

### Step 6:

1. Attach Seat (D73) to Upper seat (A2).
2. Attach Connecting tube (D1) to Bottom seat (A1) with Hexagon bolt (D17), Flat washer (D43), Nylon nut (D32).
3. Install Rope (D72) as showing blow. Attach Rope (D72) to Rear Connecting tube (D5) with Hexagon bolt (D21), Flat washer (D42), Nylon nut (D34).
4. Attach pulley cover (D65), Alloy Sleeve (D41) and Pulley (D56) to Seat tube (D2) with Hexagon bolt (D14), Flat washer (D43)
5. Attach pulley cover (D65), Alloy Sleeve (D41) and Pulley (D56) to Seat tube (D2) with Hexagon bolt (D15), Flat washer (D43), Nylon nut (D33).
6. Attach spacer bush (D50), pulley cover (D65), Alloy Sleeve (D41) and Pulley (D56) to Rear Connecting tube (D5) with Hexagon bolt (D13), Flat washer (D43), Nylon nut (D32).

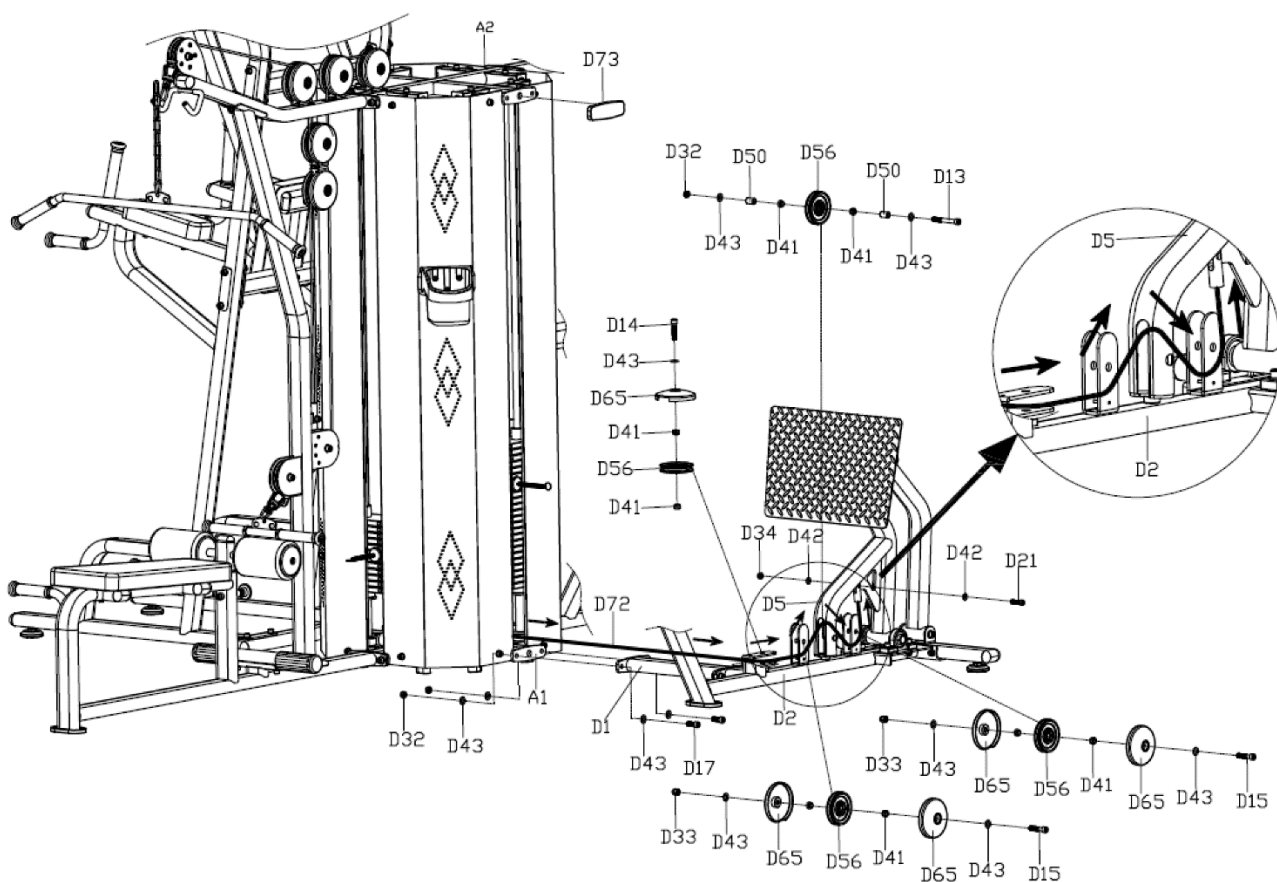

**Function E:**

**Step 1:**

1. Attach Middle tube (E4) to Left and Right tube (E1 and E2) with Hexagon bolt (E9), Flat Washer (E17), Arc splicing (E6), Nylon nut (E15), make Hexagon bolt (E9) unlocked temporarily.
2. Attach Upper tube (E5) to Left and Right tube (E1 and E2) with Hexagon bolt (E9), Flat Washer (E17), Arc splicing (E6), Nylon nut (E15), make Hexagon bolt (E9) unlocked temporarily.

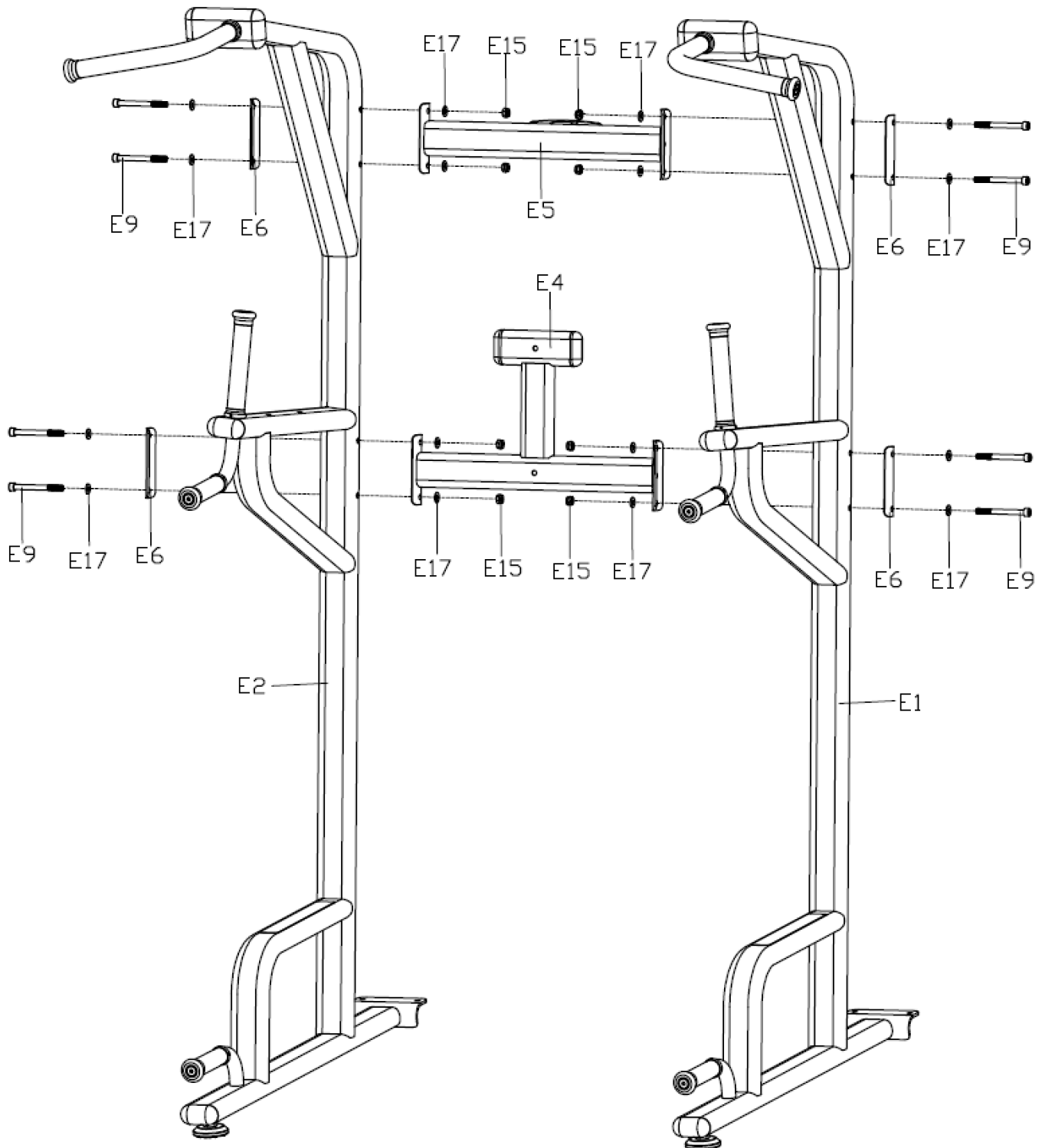



## Function E:

### Step 2:

1. Attach Bottom tube (E3) to Left and Right tube (E1 and E2) with Hexagon bolt (E8), Flat washer (E17)
2. Tighten Hexagon bolt (E9).
3. Attach Backrest (E28) to Middle tube (E4) with Hexagon bolt (E11), Flat washer (E19).

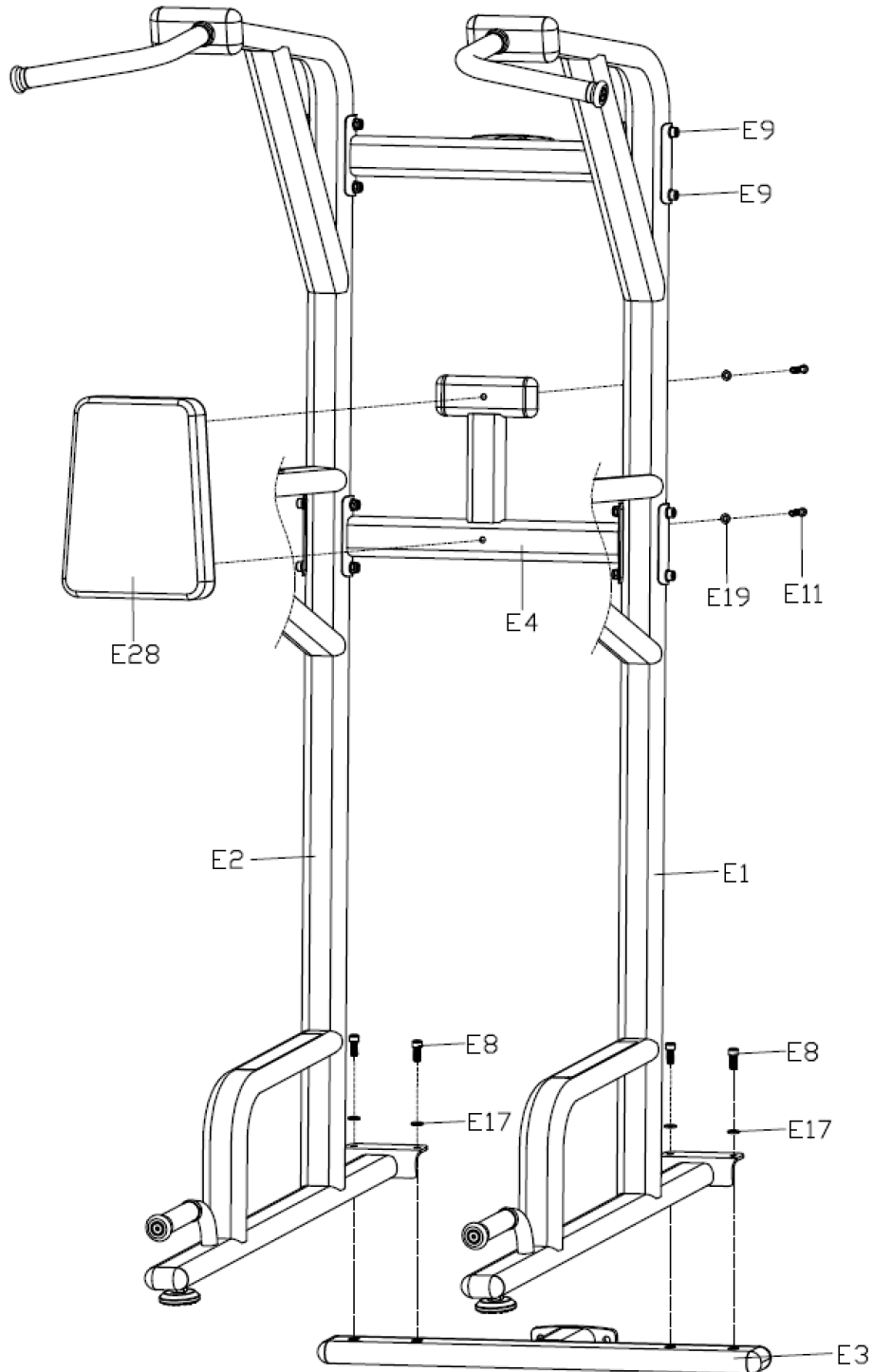

## Function E:

### Step 3:

1. Attach Handguard (E23) to Left and Right tube (E1 and E2) with Hexagon bolt (E10), Flat washer (E19)

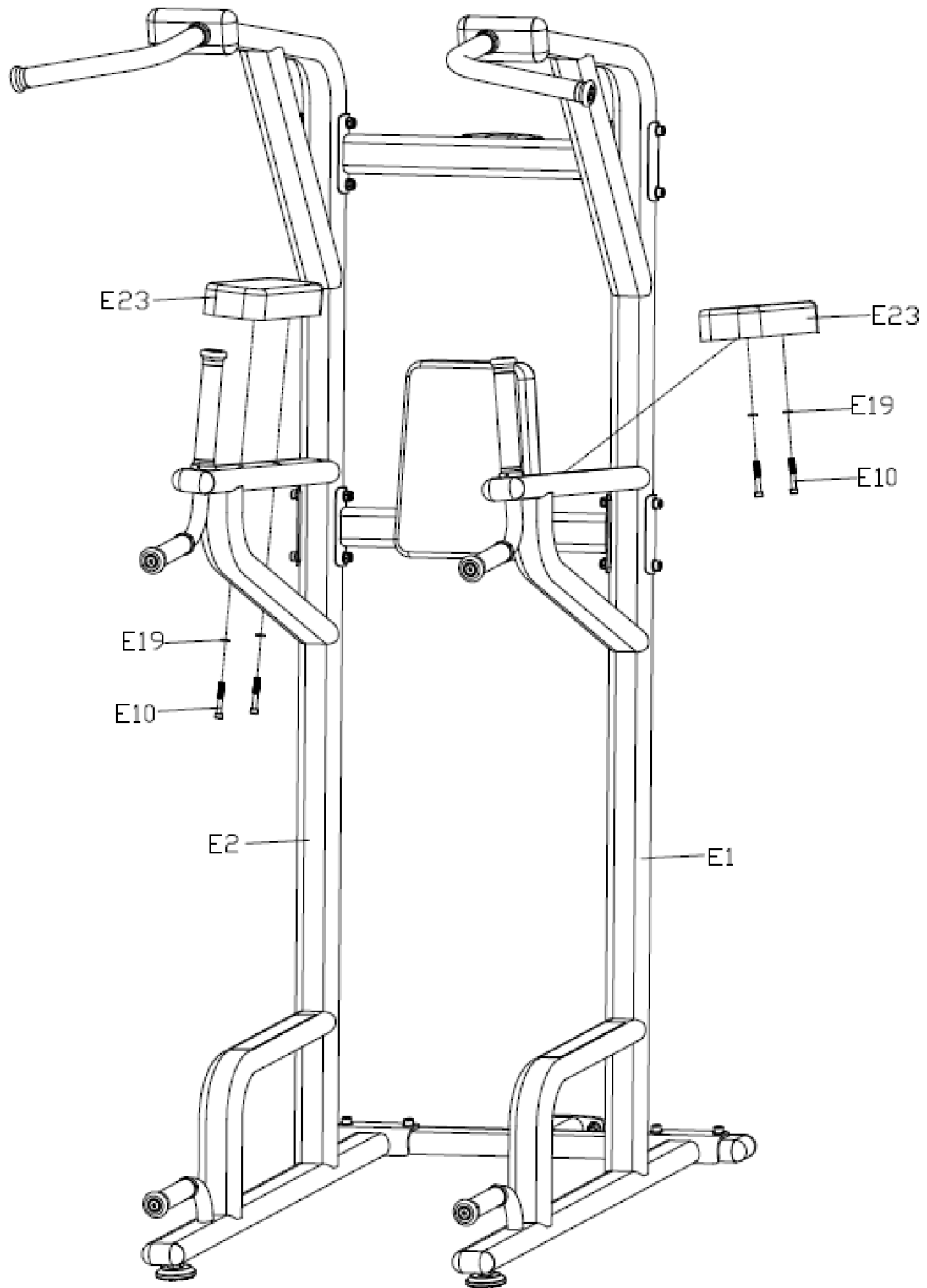

## Function E:

### Step 4:

1. Attach Bottom tube (E3) to Bottom seat (A1) with Hexagon bolt (E7), Flat washer (E18), Nylon nut (E14).
2. Attach Upper tube (E5) to Upper seat (A2) with Hexagon bolt (E7), Flat washer (E18), Nylon nut (E14).
3. Tighten Hexagon bolt (A6) on Cover (A3 and A4).

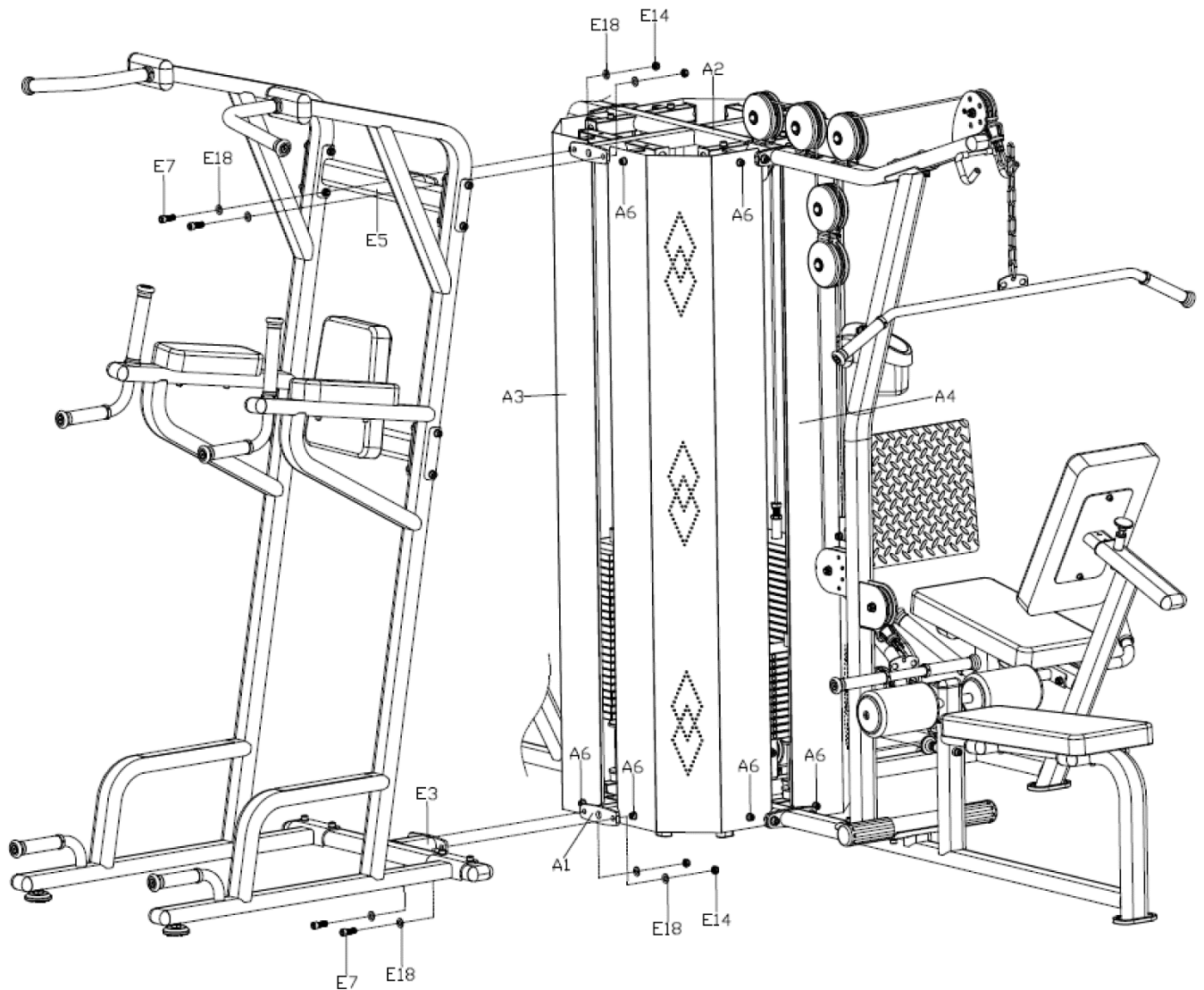

## Function F(OPTIONAL FUNCTION):

### Step 1:

1. Attach Foot pedal tube (F8) to Bottom tube (F2) with Hexagon bolt (F15), Flat washer (F24).

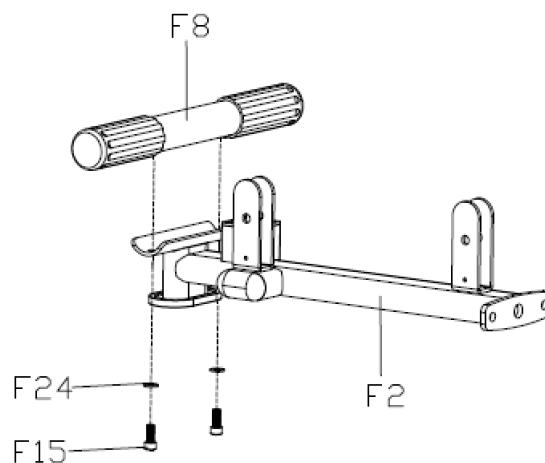

## Function F(OPTIONAL FUNCTION):

### Step 2:

1. Adjust Adjustable tube (F3) to Slip tube (F4), around Position A will be fine.

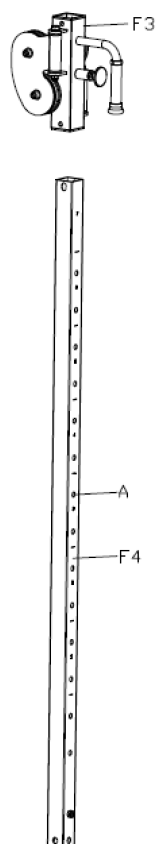

## Function F(OPTIONAL FUNCTION):

### Step 3:

1. Attach Slip tube (F4) to Bottom tube (F2) with Hexagon bolt (F9), Flat washer (F23). Nylon nut (F20), make Hexagon bolt (F9) unlocked temporarily.

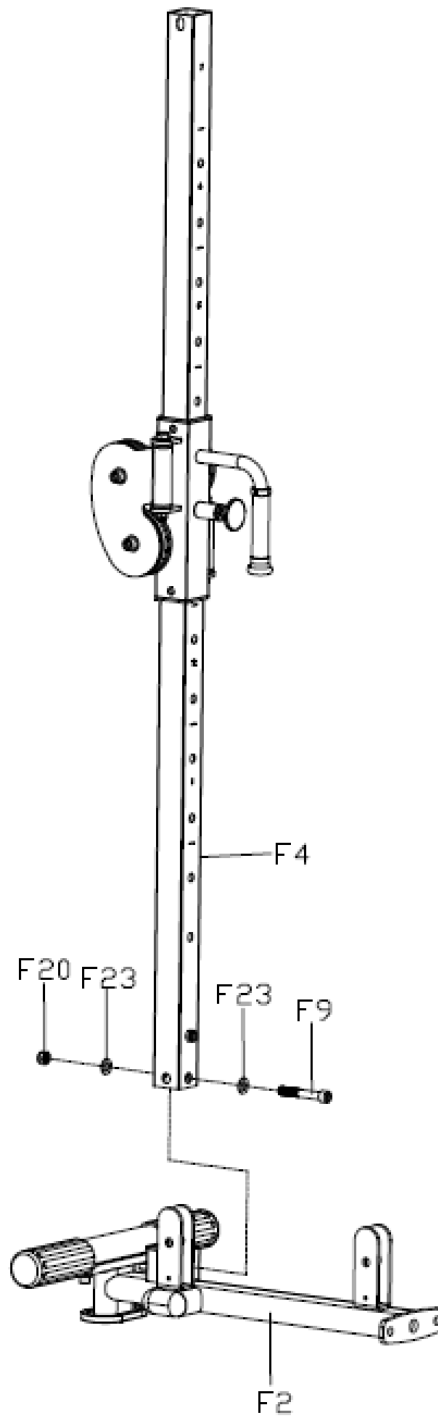

**Function F(OPTIONAL FUNCTION):**

**Step 4:**

1. Attach Upper tube (F1) to Slip tube (F4) with Hexagon bolt (F9), Flat washer (F23). Nylon nut (F20), make Hexagon bolt (F9) unlocked temporarily.

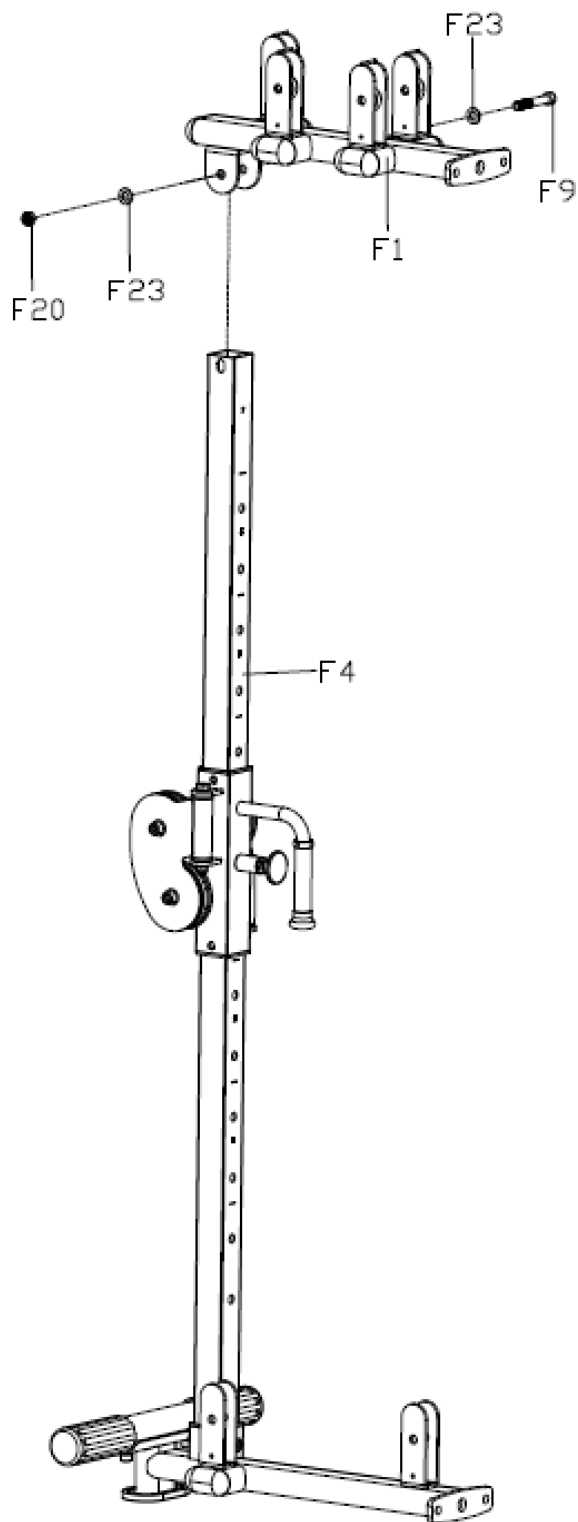

**Function F(OPTIONAL FUNCTION):**

**Step 5:**

1. Attach Upper tube (F1) and Bottom Tube (F2) to Bottom seat (A1) with Hexagon bolt (F13), Flat washer (F23). Nylon nut (F20), tighten all the screws and bolts.

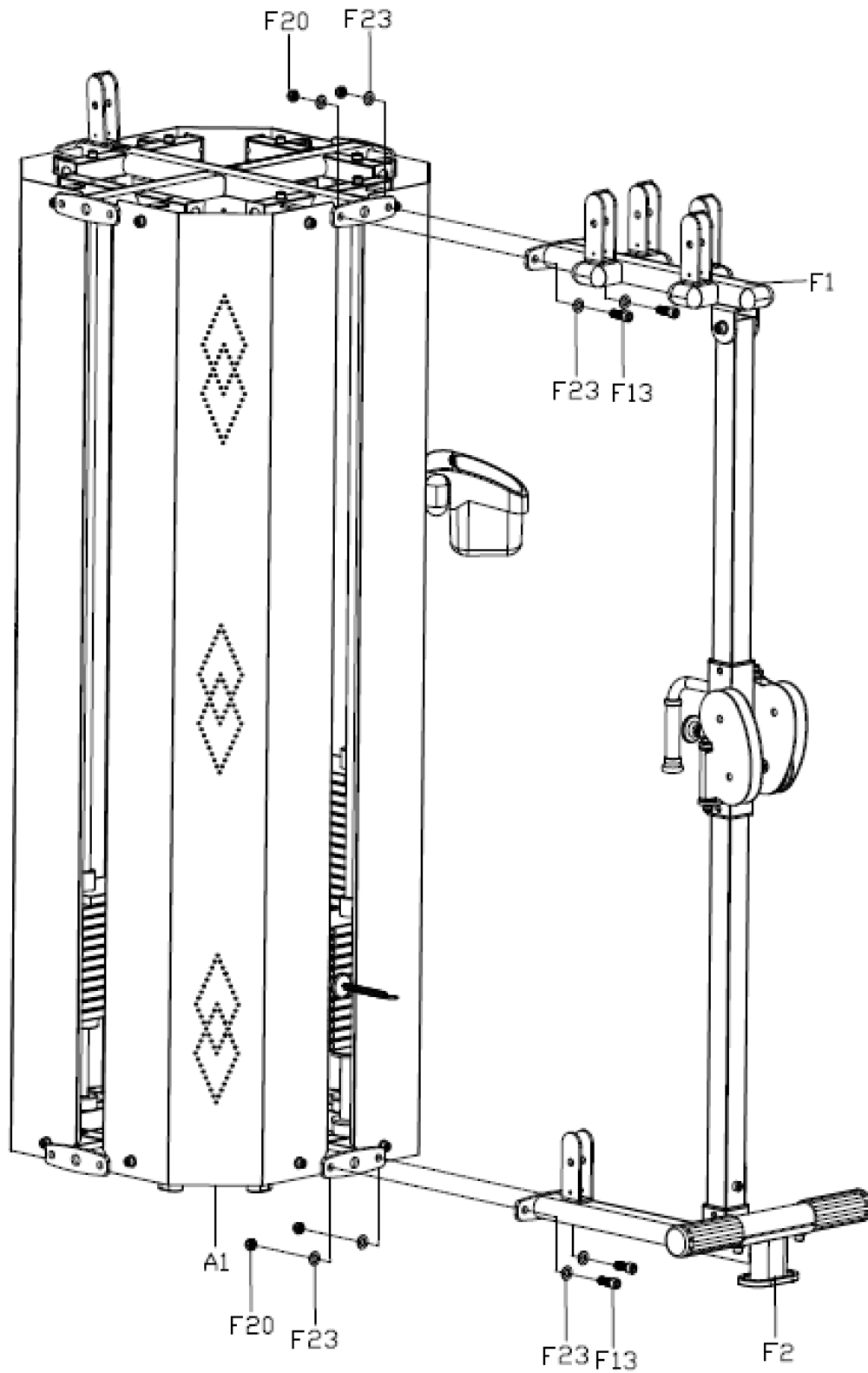

## Function F(OPTIONAL FUNCTION):

### Step 6:

1. Install Rope (F49) as showing blow. Attach Rope (F49) to Pulley bracket (F6) , tighten Flange nut (F52) after.
2. Install Rope (F48) through Guide plate (F5) as showing blow.
3. Install Rope (F48) through Rope rubber cap (F55) and attach to Hexagon rope block (F54) and screw up with Hexagon bolt (F56), then attach Hexagon rope block (F54) to Rope rubber cap (F55)
4. Attach pulley cover (F39), Alloy Sleeve (F27) and Pulley (F44) to Bottom tube (F2) with Hexagon bolt (F10), Flat washer (F23), high cap nut (F21).
5. Attach pulley cover(F39), Alloy Sleeve (F27) and Pulley (F44) to Pulley bracket (F6) with Hexagon bolt (F10), Flat washer (F23), high cap nut (F21).

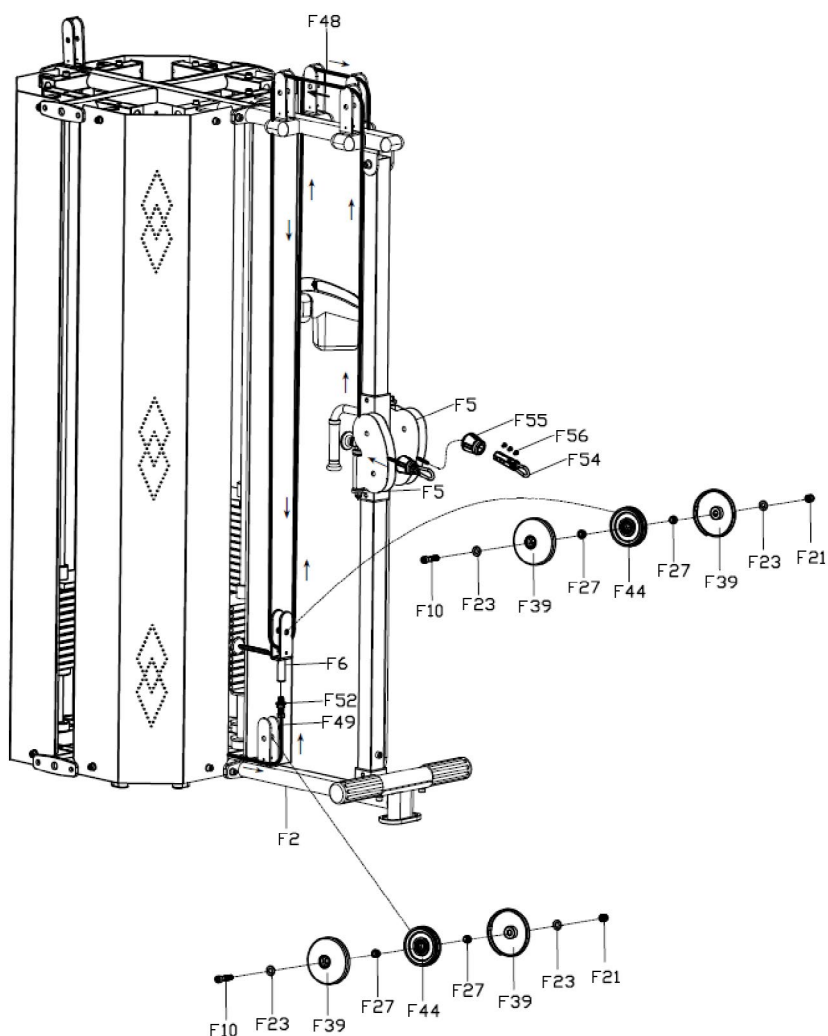



**Function F(OPTIONAL FUNCTION):**

**Step 7:**

1. Attach pulley cover (F39), Alloy Sleeve (F27) and Pulley (F44) to Upper tube (F1) with Hexagon bolt (F10), Flat washer (F23), high cap nut (F21).
2. Attach pulley cover (F39), Alloy Sleeve (F27) and Pulley (F44) to Upper tube (F1) with Hexagon bolt (F10), Flat washer (F23), Nylon nut (F20).
3. Attach pulley cover (F39), Alloy Sleeve (F27) and Pulley (F44) to Bottom tube (F2) with Hexagon bolt (F12), Flat washer (F23).

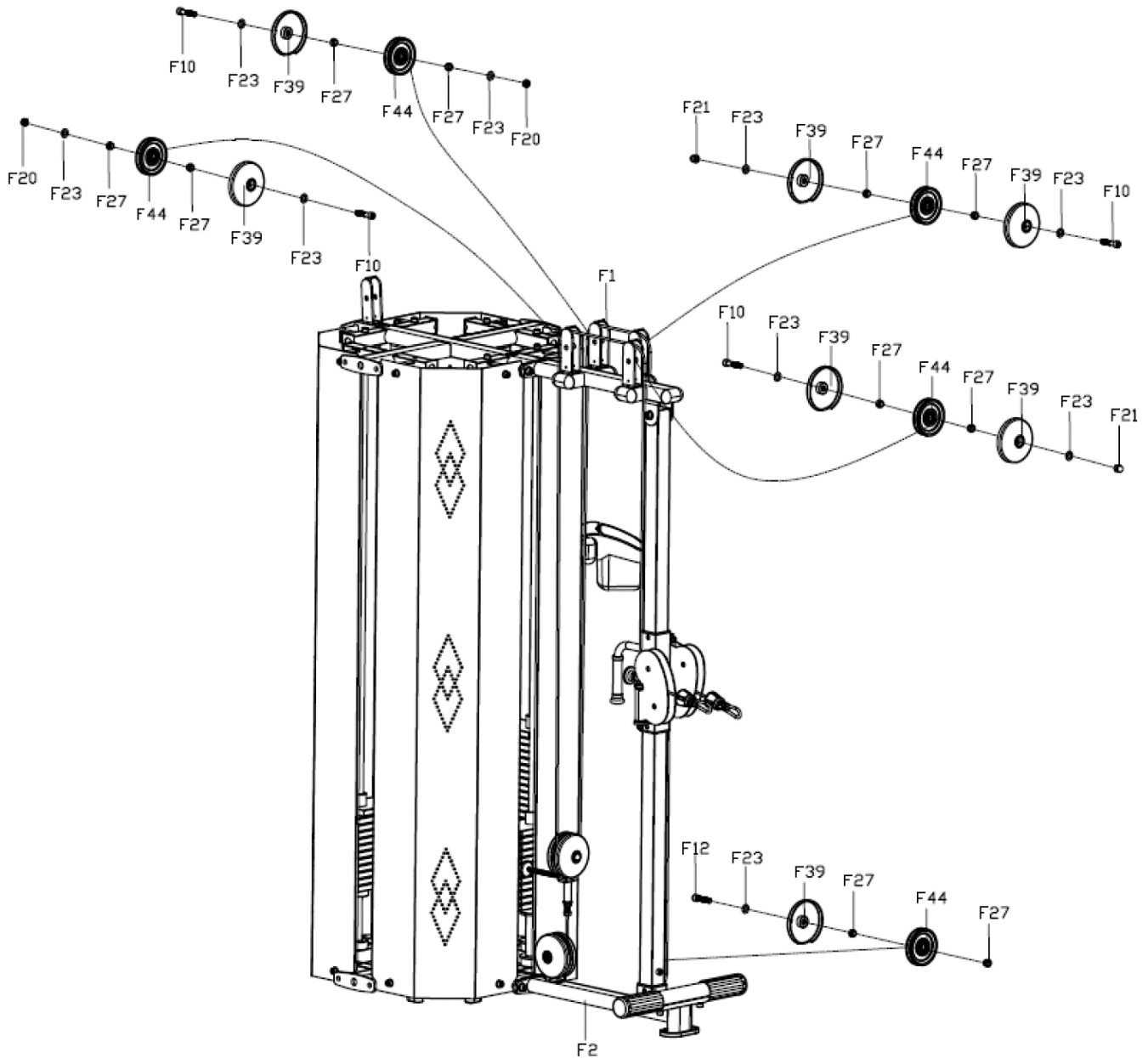

**Function F(OPTIONAL FUNCTION):**

**Step 8:**

1. Attach Alloy Sleeve (F27) and Pulley (F44) to Guide plate (F5) with Hexagon bolt (F11), Flat washer (F23), Nylon nut (F20).

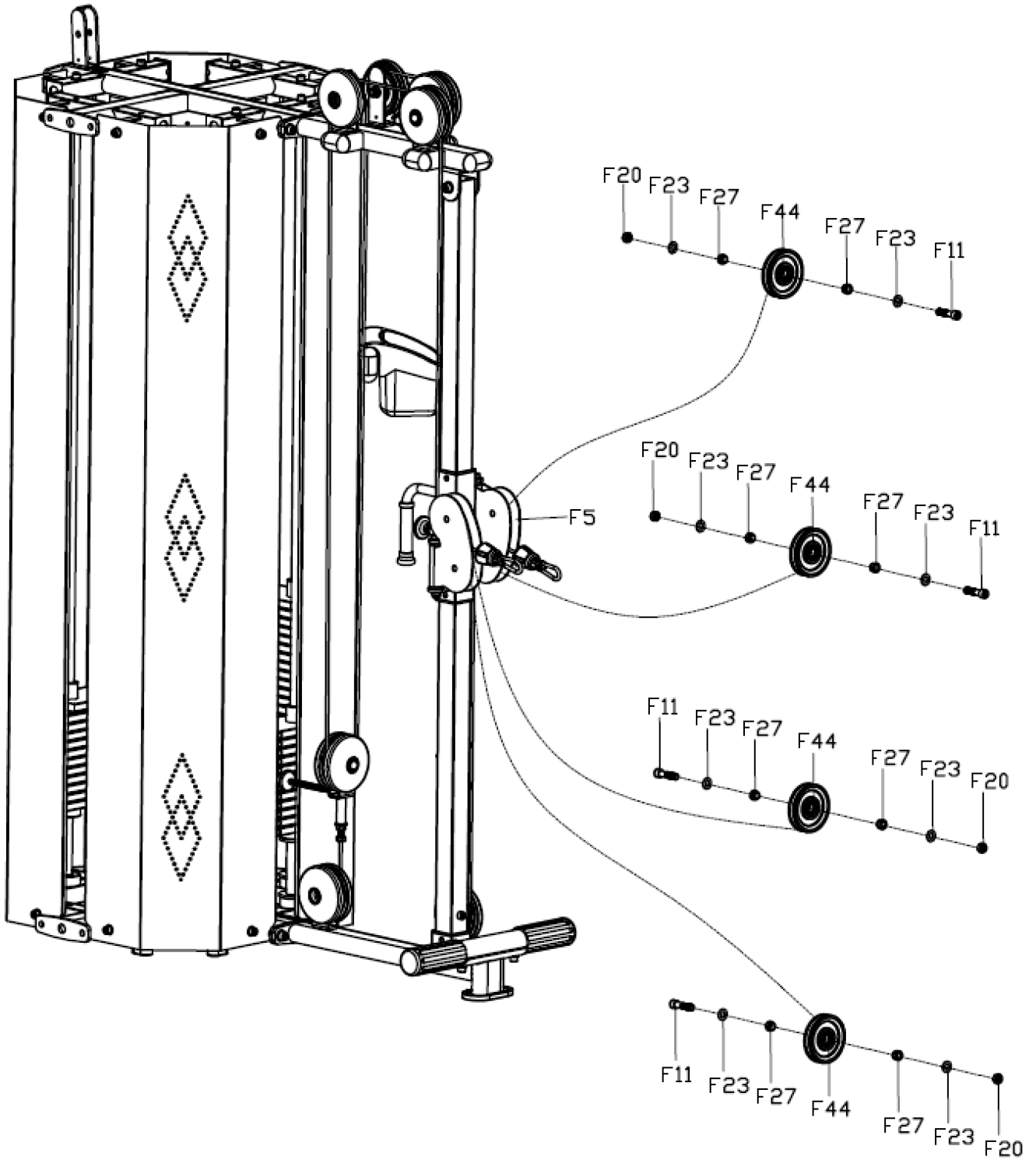

**Function F(OPTIONAL FUNCTION):**

**Step 9:**

1. Install handle bar 1 (F37) on Rope lock (F48).

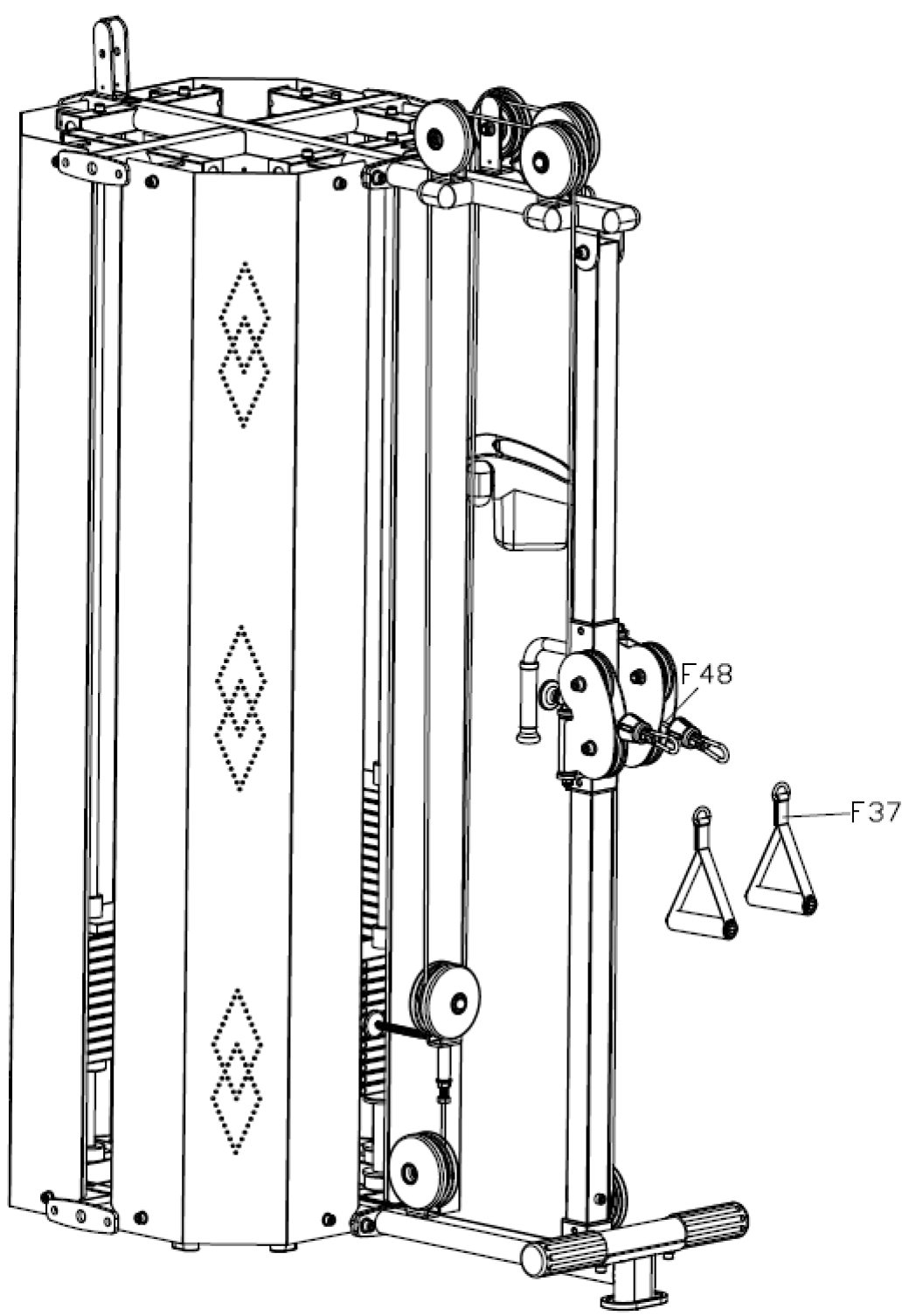

**Function G(OPTIONAL FUNCTION):**

**Step 1:**

1. Attach Connecting tube (G6) to Seat tube (G3) with Hexagon bolt (G39), Flat washer (G33), Nylon nut (G38).
2. Attach Bottom tube (G2) to Seat tube (G3) with Hexagon bolt (G27), Flat washer (G41).
3. Attach Top tube (G7) to Bottom tube (G2) and Connecting tube (G6) with Hexagon bolt (G39), Flat washer (G33), Nylon nut (G38).

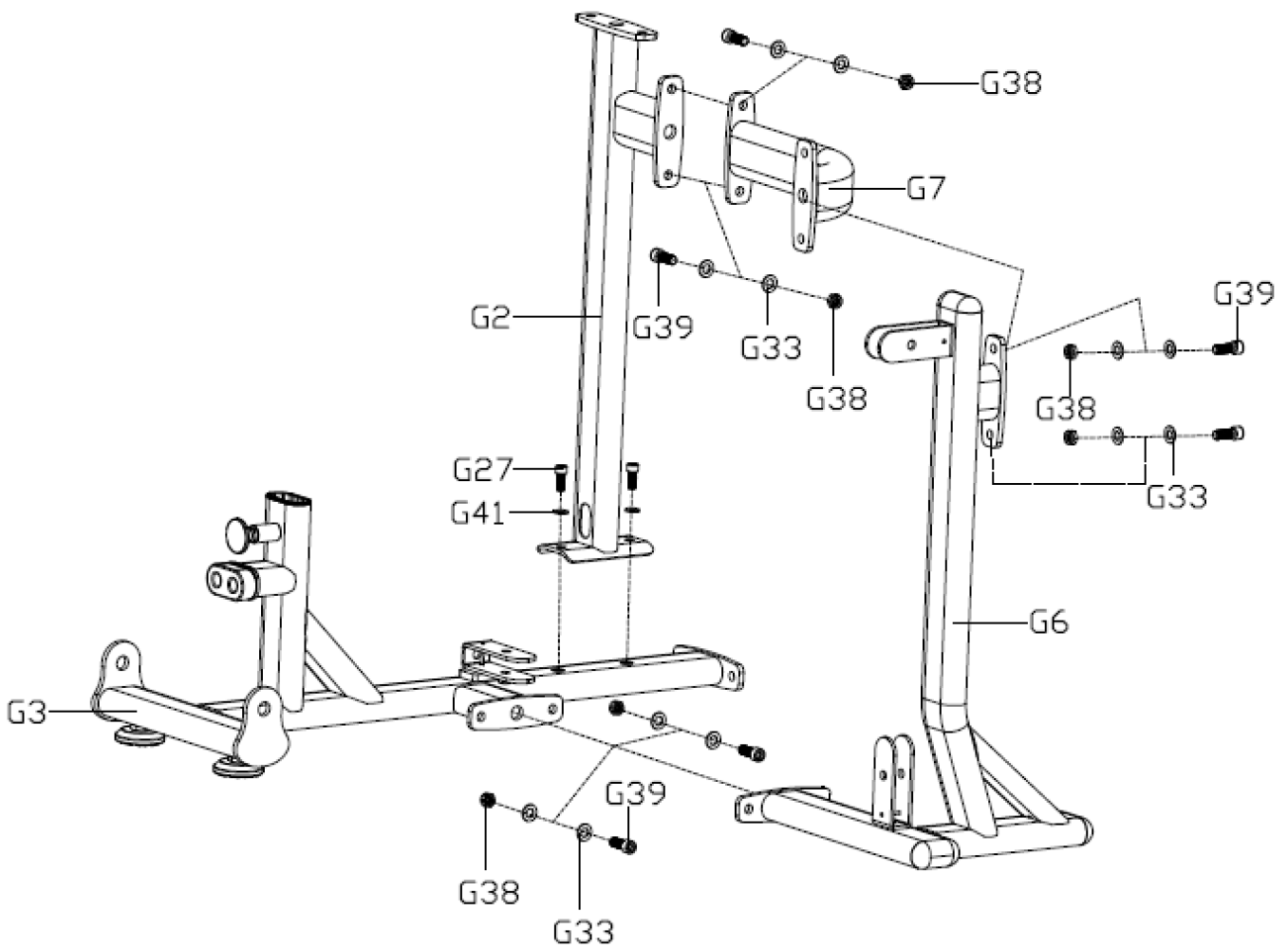

**Function G(OPTIONAL FUNCTION):**

**Step 2:**

1. Attach Seat (G30) to Seat adjusting tube (G5) with Hexagon bolt (G29), Flat washer (G21).
2. Back-out Hexagon bolt (G27), take out Bolt (G26). Attach Seat adjusting tube (G5) to Seat tube (G3), then tighten Hexagon bolt (G27) after.

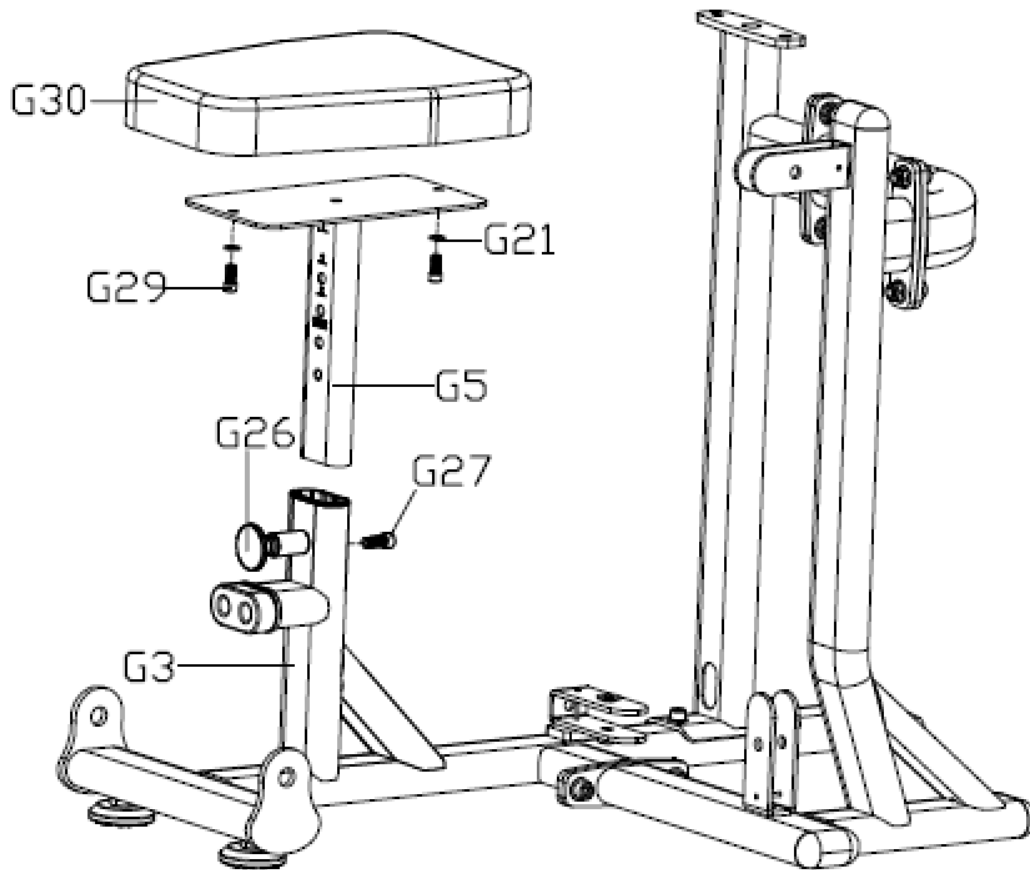

**Function G(OPTIONAL FUNCTION):**

**Step 3:**

1. Attach Upper tube (G1) to Bottom tube(G2) with Hexagon bolt (G39), Flat washer (G33), Nylon nut (G38)
2. Attach Backrest (G31) to Backrest tube (G8) with Hexagon bolt (G29), Flat washer (G21)
3. Back-out Hexagon bolt (G27), take out Bolt (G26). Attach Backrest tube (G8) to Upper tube (G1), then tighten Hexagon bolt (G27) after.

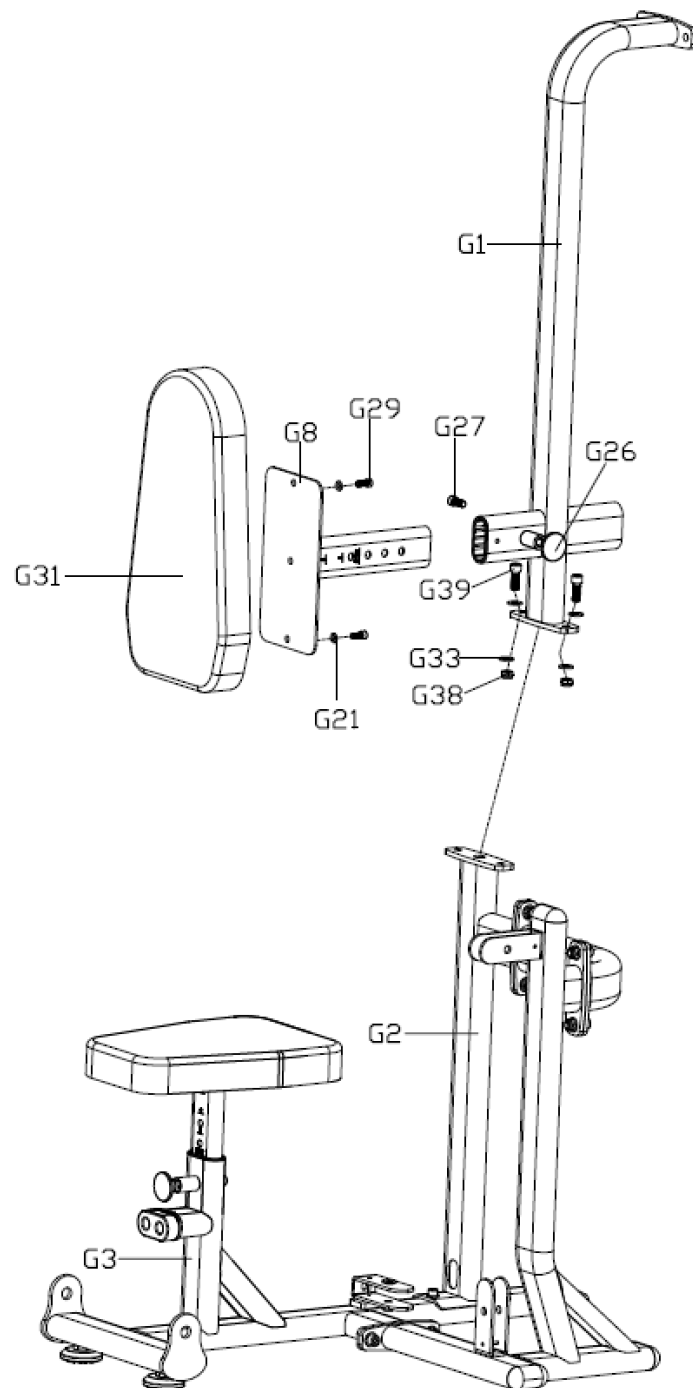

## Function G(OPTIONAL FUNCTION):

### Step 4:

1. Attach Upper tube (G1), Seat tube (G3) to Upper seat (A2) and Bottom seat (A1) with Hexagon bolt (G39), Flat washer (G33), Nylon nut (G38).
2. Install Rope (G47) as showing blow. Then attach Bearing (G45) to Arm tube(G4) with Hexagon bolt (G44), Flat washer (G33), Nylon nut (G38).
3. Attach Pulley cover (G34), Alloy Sleeve (G35) and Pulley (G37) to Seat tube (G3) with Hexagon bolt (G32), Flat washer (G33)
4. Attach Pulley cover (G34), Alloy Sleeve (G35) and Pulley (G37) to the top and bottom of Connecting tube (G6) with Hexagon bolt (G40), Flat washer (G33), Nylon nut (G42).
5. Attach Arm tube (G4) to Seat tube (G3) with Hexagon bolt (G12), End cap (G15) and Long axis (G17).

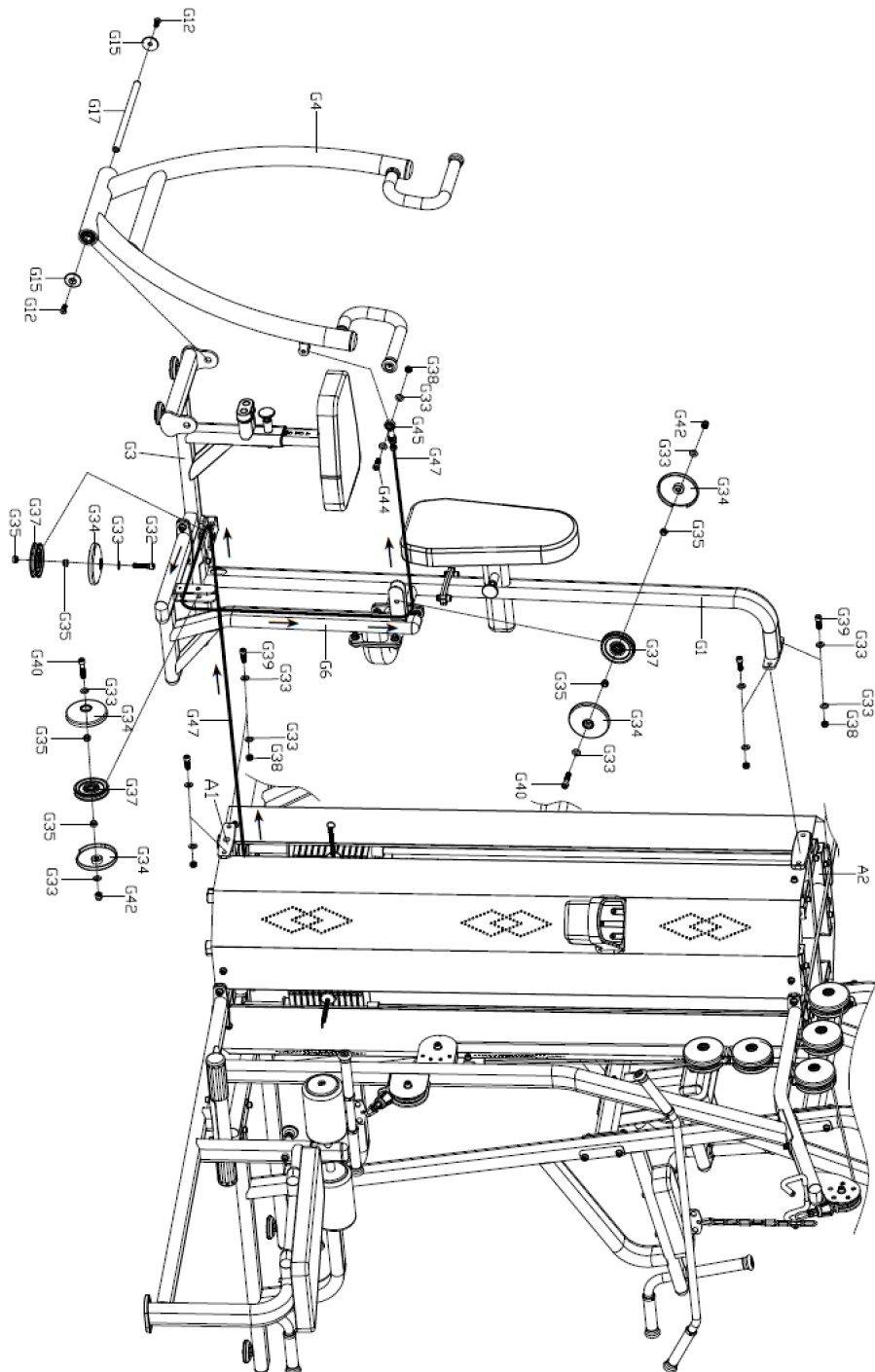

**WARNING! Consult your physician before starting with any exercise program. He can advise on the kind of training and which impact is suitable.**

**WARNING! This Multi 4 Station is not suitable for therapeutic or medical purpose.**

**WARNING! Over exercising may result in serious injury or death. If you experience dizziness, nausea, chest pain, or any other abnormal symptoms STOP EXERCISING IMMEDIATELY AND CONSULT A PHYSICIAN WITHOUT DELAY.**

**WARNING! Inappropriate use of this Multi 4 Station such as while under the influence of drugs or alcohol, not in line with instructions or excessive usage, may result serious injury or death.**

**WARNING! Incorrect/excessive training may cause health injuries.**

- ▶ The owner's manual is only for customers' reference.
- ▶ The supplier cannot guarantee for mistakes occurring due to translation or change in technical specification of the product.
- ▶ DKN-Technology ASSUMES NO RESPONSIBILITY FOR PERSONAL INJURY OR PROPERTY DAMAGE SUSTAINED BY OR THROUGH THE USE OF THIS PRODUCT



## WARRANTY

DKN-Technology warrants this product to be free from defects in material at the time of the product's tender of delivery. This 'Carry-in' Limited Warranty applies for a period of two (2) years, beginning on the date mentioned on your product invoice or proof of purchase of product issue by DKN-Technology.

This Limited Warranty is not transferable and does not cover normal wear and tear (including, but not limited to, damage and wear to batteries, springs, bearings, running mats, hydraulic systems, ropes, belts, pulleys, power shocks, drive belts and other non-durable parts, etc...).

This Limited Warranty is void if the product is damaged by accident, unreasonable use, improper service, failure to follow instructions provided, modification from its original state, or other causes determined not arising out of defects in material, the consequences of improper treatment, bad installation, wrong assembly or tampering of the parts by incorrect assembly, improper use of the machine (eg. too heavy load in time, weight etc...), problems caused by lack of maintenance, deviations of the standard machine, such as light vibrations or noise, etc...

Transport charges, travel charges for technicians, and possible trader and/ or workshop charges are excluded from this warranty, and will be at the sole cost of the owner.

The liability of the manufacturer under this Limited Warranty shall not include any liability for direct, indirect, or consequential damages resulting from any defect nor the use of this machine.

## CUSTOMER SUPPORT

Should you require any assistance regarding this product please gather the following information and then contact us using the details below:

- Product nr - This can be found on the product label
- Original purchase date
- Place of purchase
- Information about the place and conditions of use
- Precise description of the issue or defect

**IMPORTANT!!** - Please retain your sales receipt, DKN-Technology Customer Care may request proof of purchase to validate eligibility for warranty service.

Warranty cover starts from the date shown on the proof of purchase.

The best way to contact us is via [www.dkn-technology.com](http://www.dkn-technology.com).

WEBSITE



**DKN**<sup>®</sup>



[dkn-technology.com](https://dkn-technology.com)



Make an Appointment to Visit our Showroom



[sales@dkn-technology.com](mailto:sales@dkn-technology.com)