



SC PRO

OWNER'S MANUAL

WEBSITE



MANUAL



DKN®

STAIR MACHINE

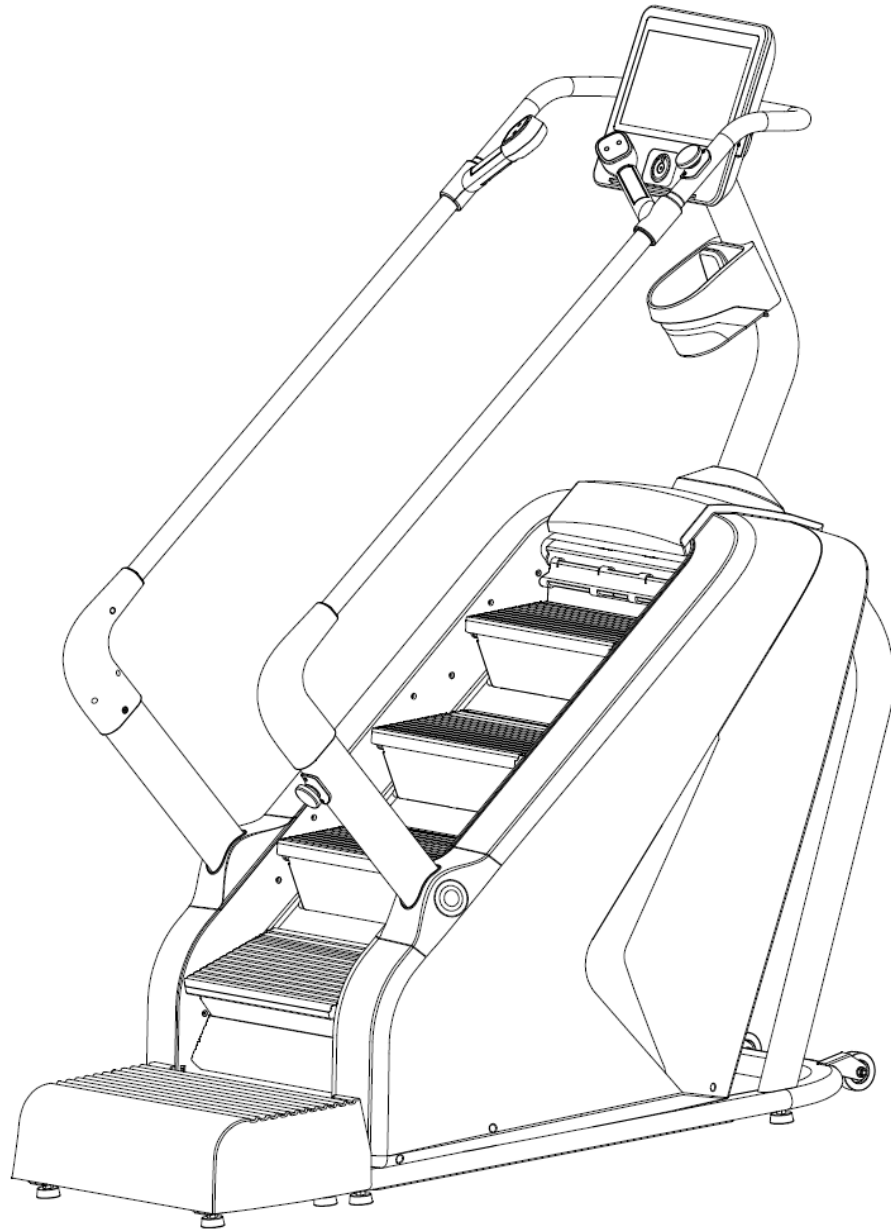

WARNING

Read all instructions carefully before using this product. Retain this owner's manual for future reference:

- When using this treadmill, keep attaching the safety pull pin rope to your clothes.
- When you are running, keep your hand swinging natural, stare forward, never look down at your feet.
- Add the speed step by step when running.
- When emergency happens, take away the "emergent stop button" immediately.
- Leave the treadmill after the running belt stop stably.

Caution: Read the assembly instruction carefully, follow the instruction when assemble.

ATTENTION

- 01- Before starting any exercise program, consult with your physician or health professional.
- 02- Check all the bolts locked.
- 03- Never put the treadmill in the wetness area, or it will cause troubles.
- 04- We take no responsibility for any troubles or hurts due to above reasons.
- 05- Dress sport clothes and shoes before running.
- 06- Do not do exercise in 40 minutes after meal.
- 07- To prevent hurts, please warm up before exercise.
- 08- Consult with doctor before exercise if you have high blood pressure.
- 09- The treadmill is only used for adults.
- 10- Provide the olds, children and handicapped with good care, guide and supervision.
- 11- Do not plug anything into any parts of this equipment, or it may damage.
- 12- Do not connect line to the middle of cable; do not lengthen cable or change the cable plug; do not put any heavy thing on cable or put the cable near the heat source; forbid using socket with several holes, these may cause fire or people may be hurt by the power.

- 13- Cut off the power when the equipment is not used. When the power is cut off , do not pull the power line to keep the wire unbroken.
- 14- Maximum weight of user: 180 KGS.
- 15- Pulse monitor data may not be accurate, can not be used for medicine. Over-exercise may cause injury, even death. If you have a feeling of dizziness, sickness or other abnormal symptoms, please stop training and consult a doctor immediately.

IMPORTANT SAFETY PRECAUTION

1. Plug the power cord of the treadmill directly into a dedicated grounded circuit. This product must be grounded. If it has breakdown, grounding provides a path of least resistance for electric current to reduce the risk of electric shock.
2. Position the treadmill on a clear, level surface. Do not place the treadmill on thick carpet as it may interfere with proper ventilation. Do not place the treadmill near water or outdoors.
3. Position treadmill so that the wall plug is visible and accessible.
4. Never start the treadmill while you are standing on the walking belt. After turning the power on and adjusting the speed control, there may be a pause before the walking belt begins to move, always stand on the foot rails on the sides of the frame until the belt is moving.
5. Wear appropriate clothing when exercising on the treadmill. Do not wear long, loose fitting clothing that may be caught in the treadmill. Always wear running or aerobic shoes with rubber soles.
6. Make sure the power supply is connected and the safety lock is effective before using the treadmill. Fit one side of the safety lock on the treadmill and clip the other side on your clothes or belt, which will enable you to pull off the safety lock promptly in an emergency.
7. Always unplug the power cord before remove the treadmill motor cover.
8. Make sure there is no less than 2*1m space behind the treadmill.
9. Keep small children away from the treadmill during operation.
10. Always hold the handrails when initially walking or running on the treadmill, until you are comfortable with the use of the treadmill.

10. Always attach the safety pull pin rope to your clothing when using the treadmill. If the treadmill should suddenly increase in speed due to an electronics failure or the speed being inadvertently increased, the treadmill will come to a sudden stop when the pull pin is disengaged from the console.

12. In case of any abnormality during the use process, please remove the safety lock immediately, grasping the handlebar and jumping onto the two edgings, then get off the treadmill after it stops.

13. When the treadmill is not being used, the power cord should be unplugged and the safety pull pin removed.

14. Put the safety key away where can not be reached by the children. Minors must be accompanied by the adults when using the treadmill.

15. Before starting any exercise program, consult with your physician or health professional. He or she can help establish the exercise frequency, intensity (target heart zone) and time appropriate for your particular age and condition. If you have any pain or tightness in your chest, an irregular heartbeat, shortness of breath, feel faint or have any discomfort while you exercise, STOP! Consult your physician before continuing.

16. If you observe any damage or wear on the mains plug or on any section of the mains lead then please have these replaced immediately by a qualified electrician – do not attempt to change or repair these yourself.

17. If the supply cord is damaged, it must be replaced by the manufacturer, its service agent or similarly qualified persons in order to avoid a hazard.

18. Put your feet on the side rail before using the treadmill, and always attach the safety pull pin rope to your clothing. Hold the handle bar before the running belt moving well (feel the running speed by your single foot before using it). To avoid loss balance, please slow down the speed to the lowest or take off the safety. And hold the handle bar to jump to the side rail when emergency or the safety key is not attached.

19. Make sure the treadmill has stopped before folding. Please don't operate it after folding the treadmill.

WARNING! Consult your physician before starting with any exercise program. He can advise on the kind of training and which impact is suitable.

WARNING! This machine is not suitable for therapeutic or medical purpose.

WARNING! Over exercising may result in serious injury or death. If you experience dizziness, nausea, chest pain, or any other abnormal symptoms STOP EXERCISING IMMEDIATELY AND CONSULT A PHYSICIAN WITHOUT DELAY.

WARNING! Inappropriate use of this machine such as while under the influence of drugs or alcohol, not in line with instructions or excessive usage, may result serious injury or death.

WARNING! Incorrect/excessive training may cause health injuries.

- ▶ The owner's manual is only for customers' reference.
- ▶ The supplier cannot guarantee for mistakes occurring due to translation or change in technical specification of the product.
- ▶ DKN-Technology ASSUMES NO RESPONSIBILITY FOR PERSONAL INJURY OR PROPERTY DAMAGE SUSTAINED BY OR THROUGH THE USE OF THIS PRODUCT

ASSEMBLY STEPS

STEP 1:

1. Open the package, take out all parts and place the main frame(1) on the flat ground.
2. Fasten the part A of pedal(40)(as P1 shows) to the part B of the main frame, please make sure the two parts are centred.

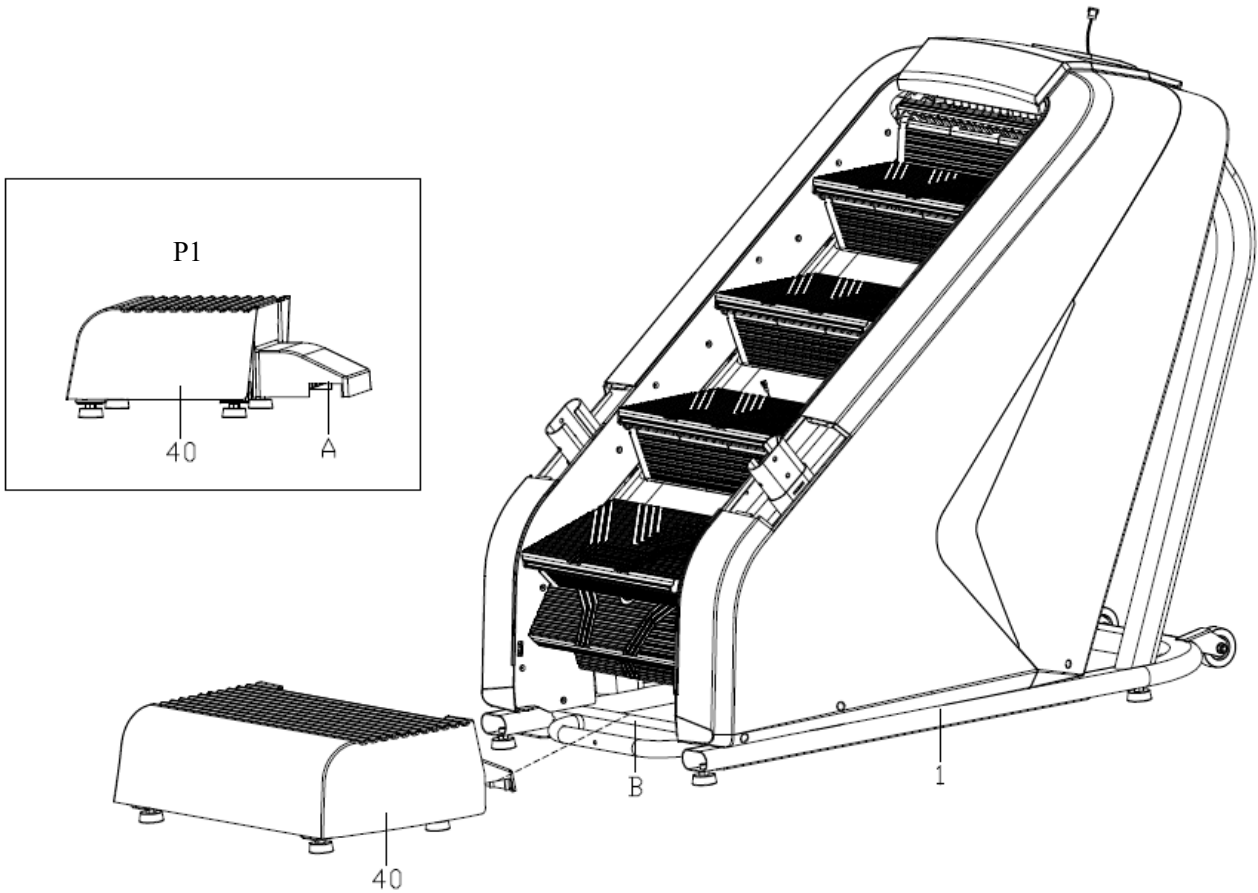

STEP 2:

1. Connecting the Console extension wire (104) to the lower wire (105);
2. Assemble the support column(5) on the main frame(1) with screw(68), and washer(95);
DO NOT TIGHTEN NOW.
3. Insert the decorative cover (58) and to the support column(5), then buckle it on the main frame(1).

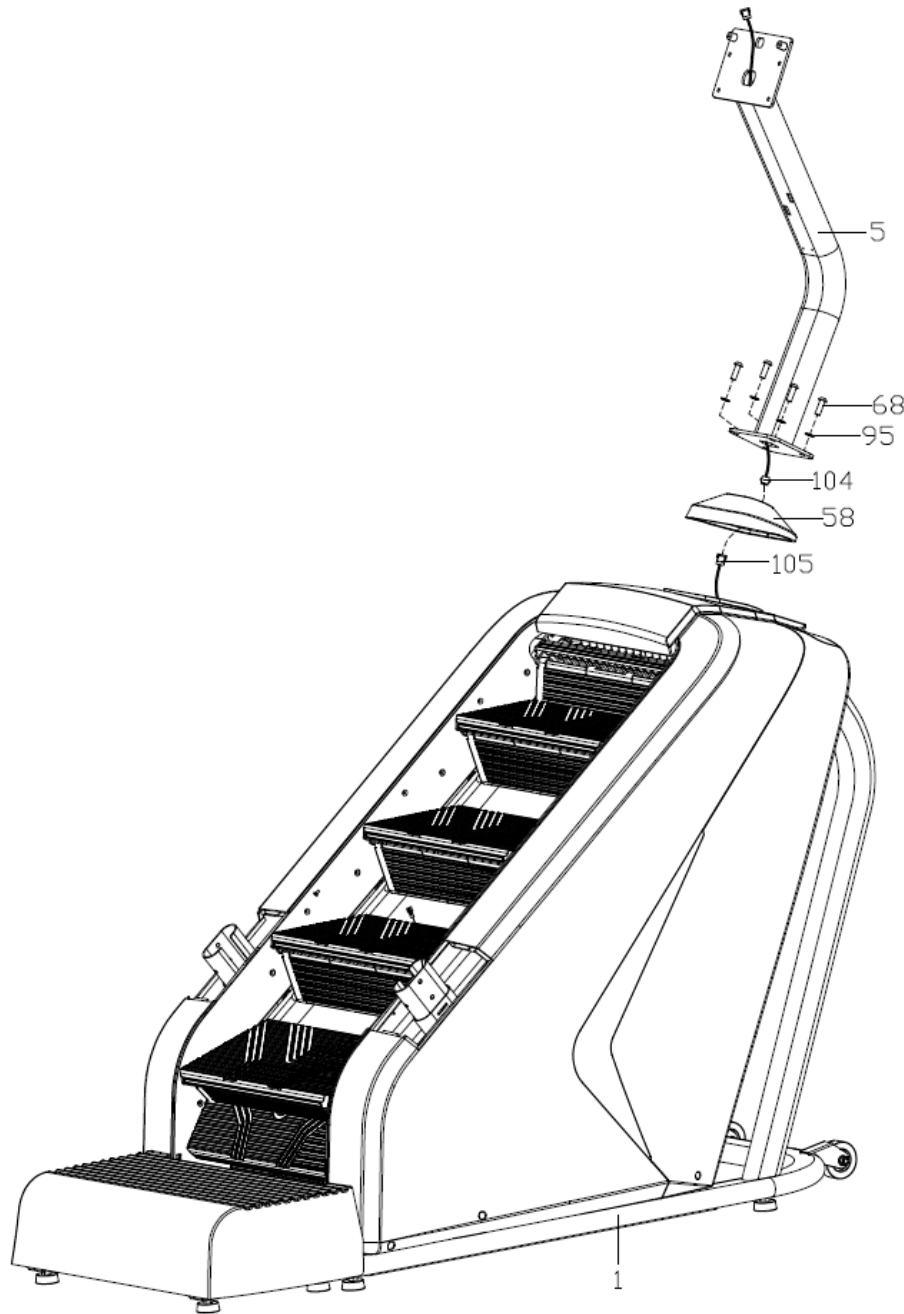

STEP 3:

- 1: Pass the switch upper wire 1(106) through the right decorative cover (41R) to connect with the lower wire1 (107);
- 2: Insert the decorative cover (41L / R) on the support column (2L / R), assemble but not tighten the support column (2L / R) on the main frame(1) with screw(69) and washer(95),
- 3: Assemble but not tighten the handrail(3L/R) on the support column (2L / R) with screw(73) and washer(96)

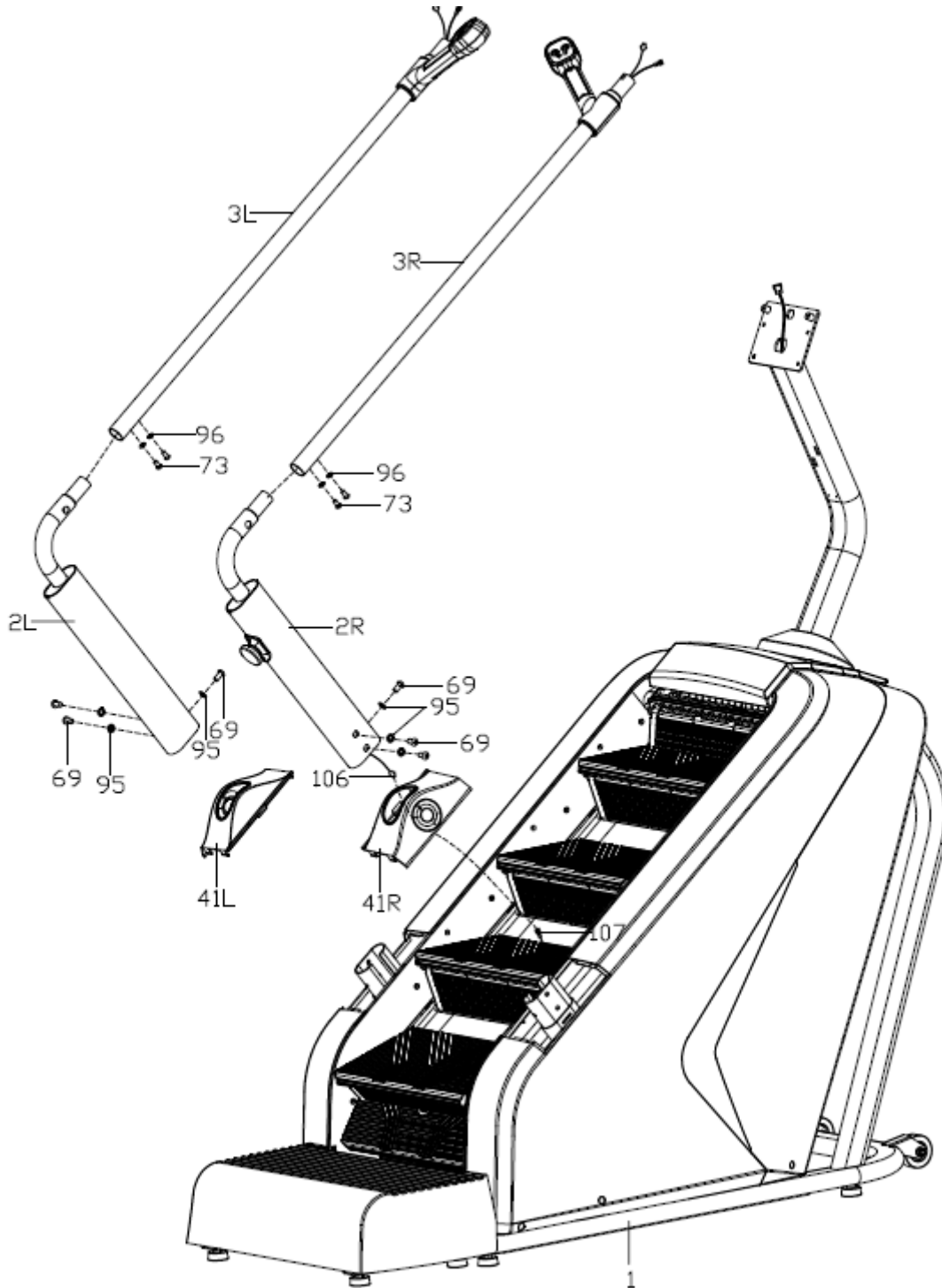

STEP 4

- 1: Connect the pulse extension wire 1 (111) to the pulse extension wire 2 (112); connect the key board extension wire 1 (115) to the key board extension wire 2 (116);
- 2: Insert the rear handrail(4) to the handrail (3L / R), then assemble but not tighten the rear handrail(4) to the handrail (3L / R) with screw(73) and washer(96);
- 3: Assemble but not tighten the rear handrail(4) on the support column(5) with screw(72);
- 4: Tighten all the screws now;
- 5: Fasten the decorative cover (41L / R) on the main frame (1);
- 6: Lock the decorative cover (44L/ R) and (45L / R) on the support column (2L / R) with screw (79) and (82).

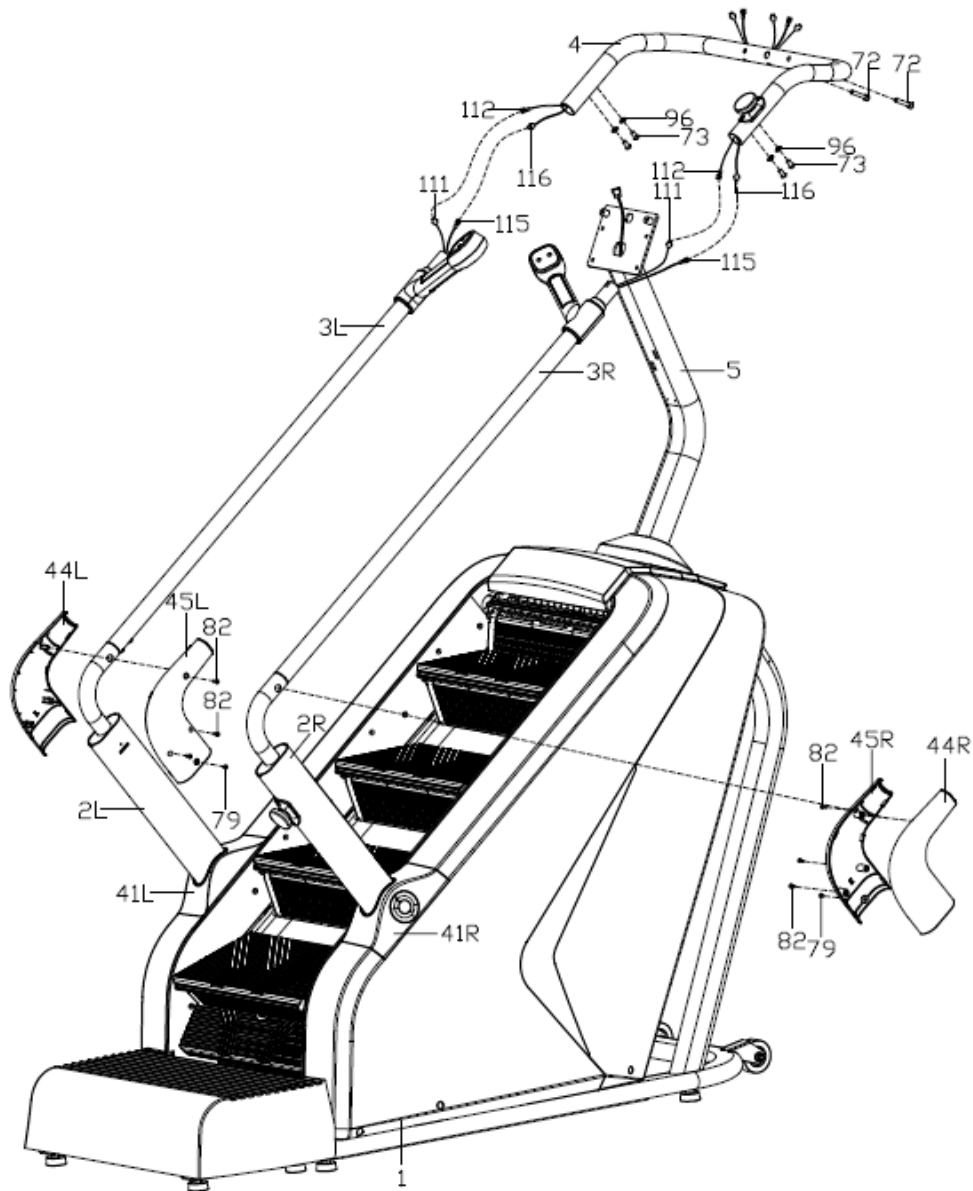

STEP 5:

1: As shown in Figure 1, connect the wires on the console (47) with the corresponding on the rear handrail (4) and the console support column (5); (matched by the same wire number)

2: Tighten the console (47) on the support column (5) with screw (78), then lock the decorative cover(48) on the console (47) with screw(82);

3: Lock the water bottle holder (49) on the support column (5) from top to bottom, tighten with screw(78).

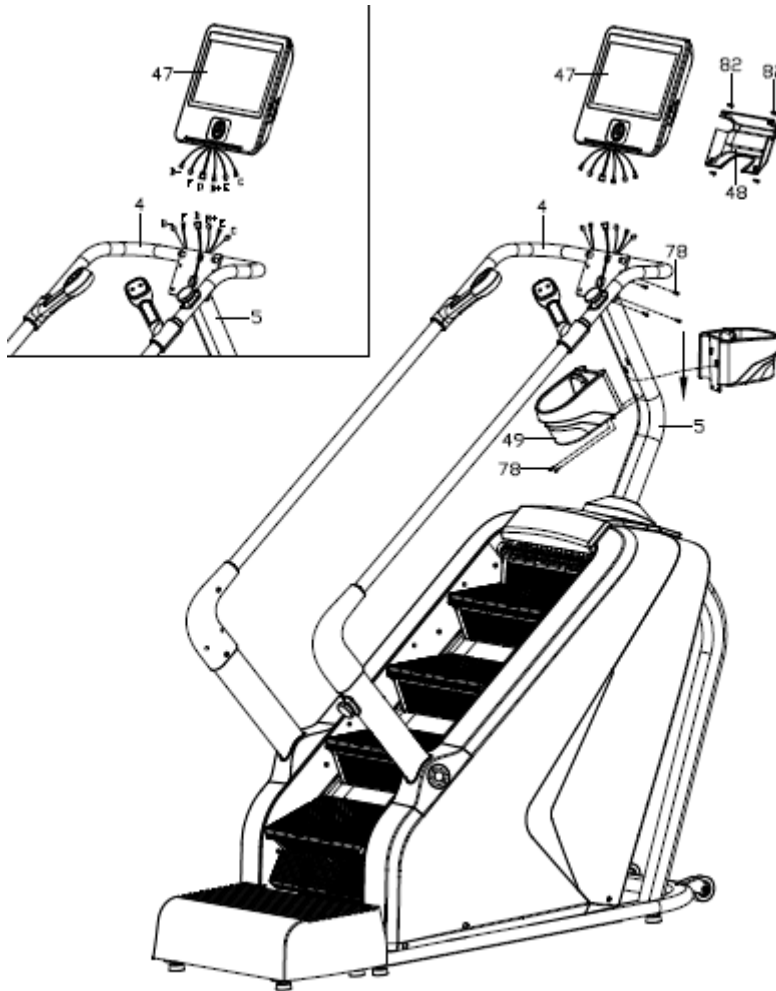

Console manual

I: Start

1. Turn on the power switch, unscrew the two emergency stop switches, and ensure that there is no obstruction in the infrared induction area

2. Press the armrest button  or tap the screen  stepper to start in the lowest gear.

3. Press the armrest button as needed   or tap on the screen

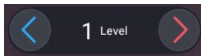
 adjust the speed gear, the speed gear range is 1-25.

4. Press the armrest button during operation  or tap the

screen  the stepper stops slowly.

II、Function introduction

◆ **USB/Headset function/Wireless charging function/Music Bluetooth:**

USB: USB interface to read the audio and video data of the USB stick

: Audio output (headphones)

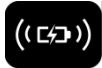
: Can charge a phone with wireless charging

Music Bluetooth name: SYMK

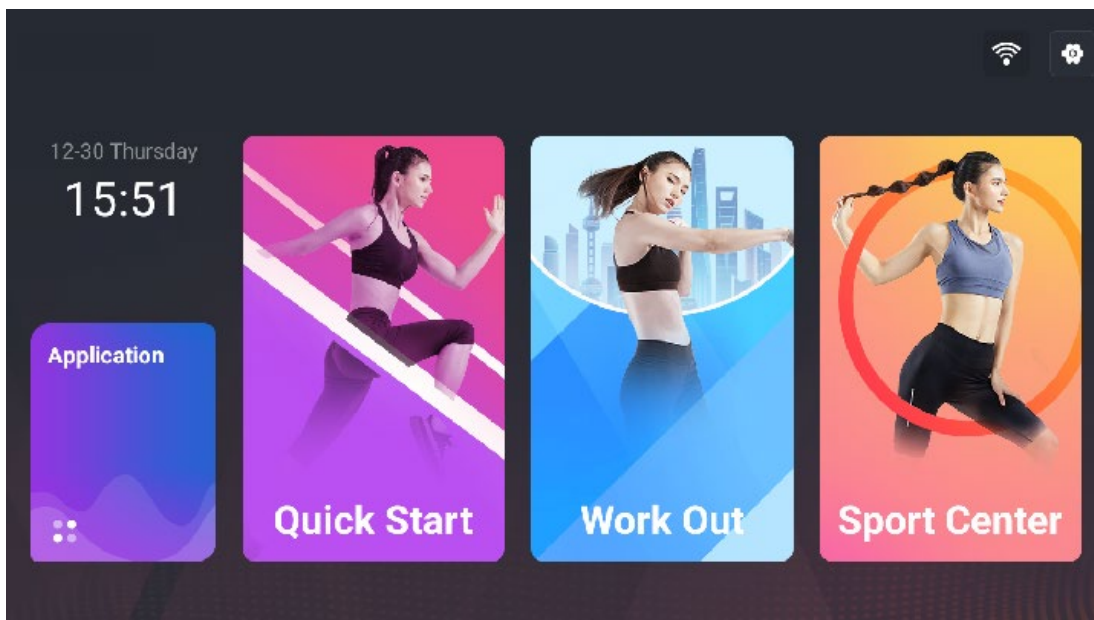

III、Main interface

The main interface is divided into six functional modules: **time and date, quick start, program exercise, application, settings, and sports center** (built-in time countdown, calorie countdown, height countdown, step countdown, floor mode, custom)

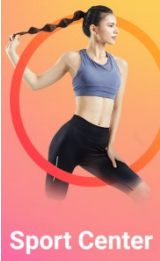

◆ The controls of the main interface are explained in detail:

icon	Function Description	icon	Function Description
	Time date Used to display the current time and date		apply Built-in third-party music APP, third-party video APP; Internet, social, news.
	Get started quickly Start exercising quickly		Program motion Built-in 36 kinds of programs

 <p>Sport Center</p>	<p>Sports center Built-in 6 ways of exercising: Time Countdown, Calorie Countdown, Height Countdown, Step Countdown, Floor Mode, Custom</p>		<p>Set up Built-in basic settings (brightness adjustment, volume adjustment, language selection, machine management, factory mode, one-click cleanup) and WIFI settings.</p>
	<p>WIFI icon: Used to see if the system is connected to a WIFI network</p>		

◆ Feature breakdown

1.1 How to manually adjust the time, date, and geographic location:

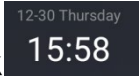
- (1) Click  Weather forecast icon time display, you can manually adjust the time and date

parameters:

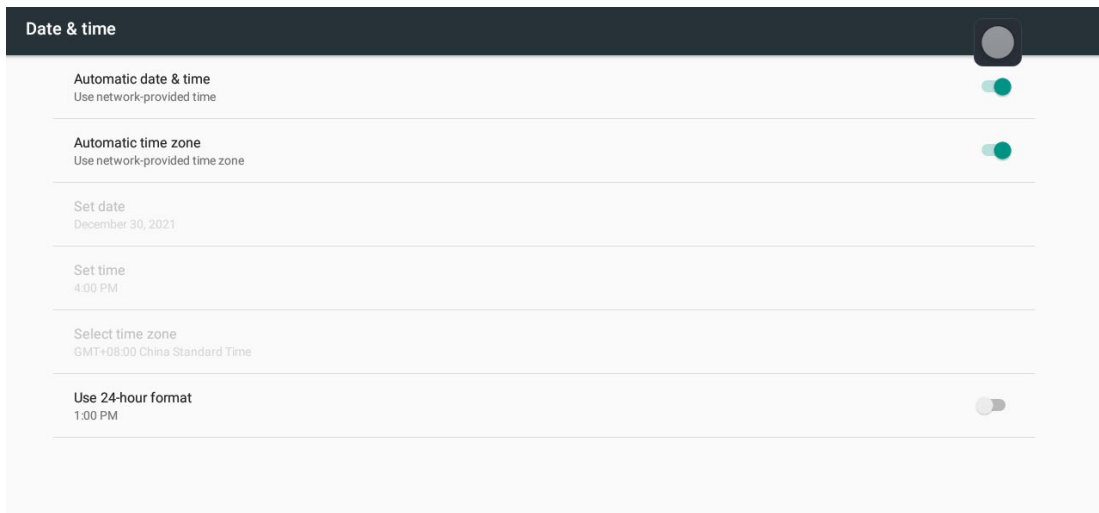

2. Application

Built-in third-party music and video APP applications

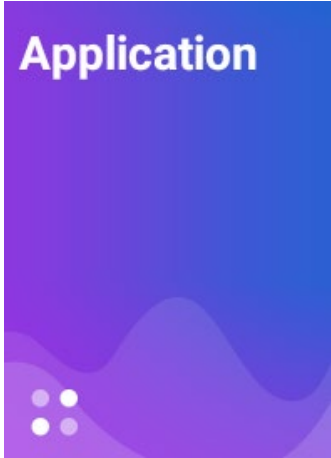
	<ul style="list-style-type: none"> ◆ The five functional modules of the Internet all need to be connected to the WIFI network to be used; ◆ Support playback of MP3, MP4, MOV, APE, and other common audio and video format files; ◆ Please try not to browse web content or watch video files when exercising, so that it is easy to be distracted and cause accidental injury; you can first complete the content setting, and then start the stepper; ◆ Listen to some relaxing music during the exercise process to reduce the boring feeling during the exercise process.
---	--



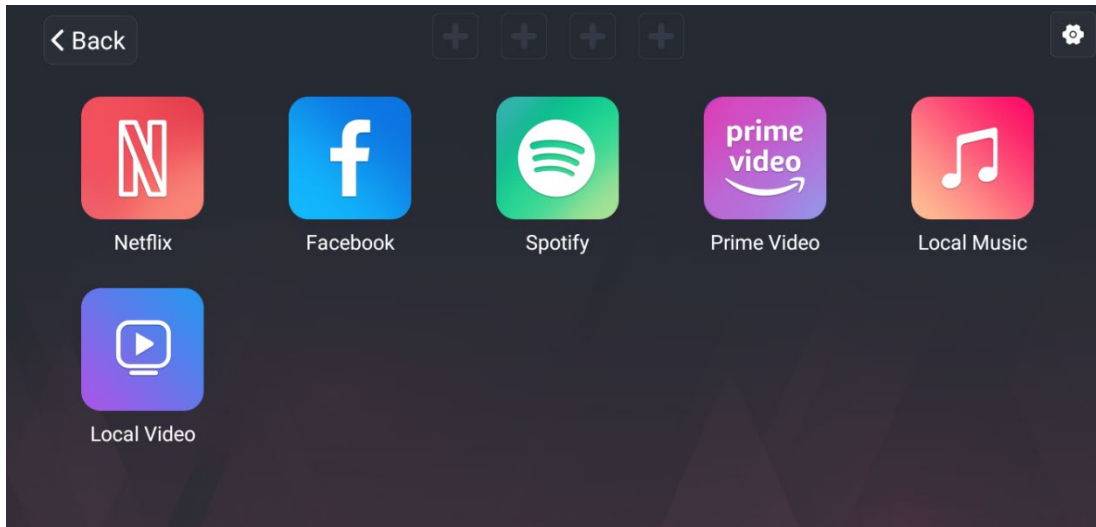

Application
tapicon, Enter the application interface:

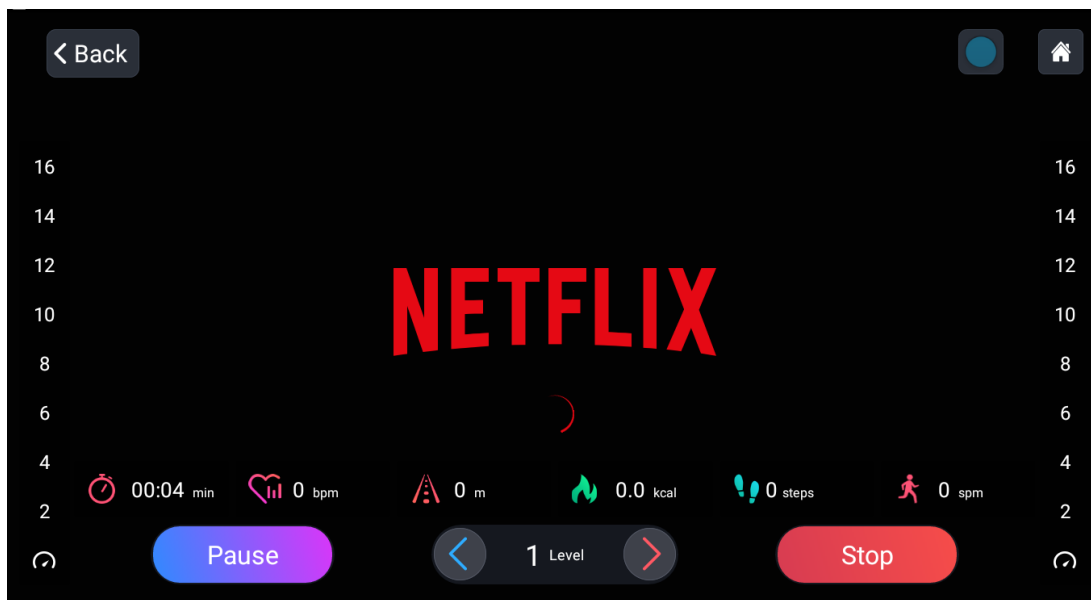

◆ Introduction to the motion interface in third-party

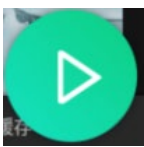
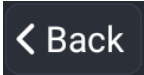

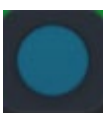

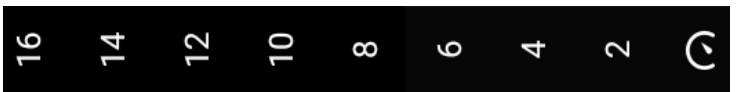
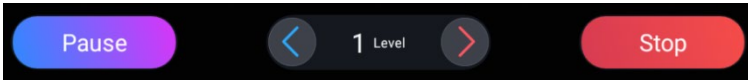
Control catalog	
	Start button: Click to start the stepper
	Back key: Click to return to the previous layer
	Main interface key: Click to return to the main interface
	Hide button: Click to show or hide the operator interface
	Displays the current motion data
	Quick keys
	Pause key, speed gear plus or minus key, stop key

3、Get started quickly

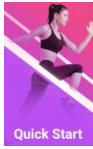

tap icon, Start the 3, 2, 1 countdown to enter the motion interface:

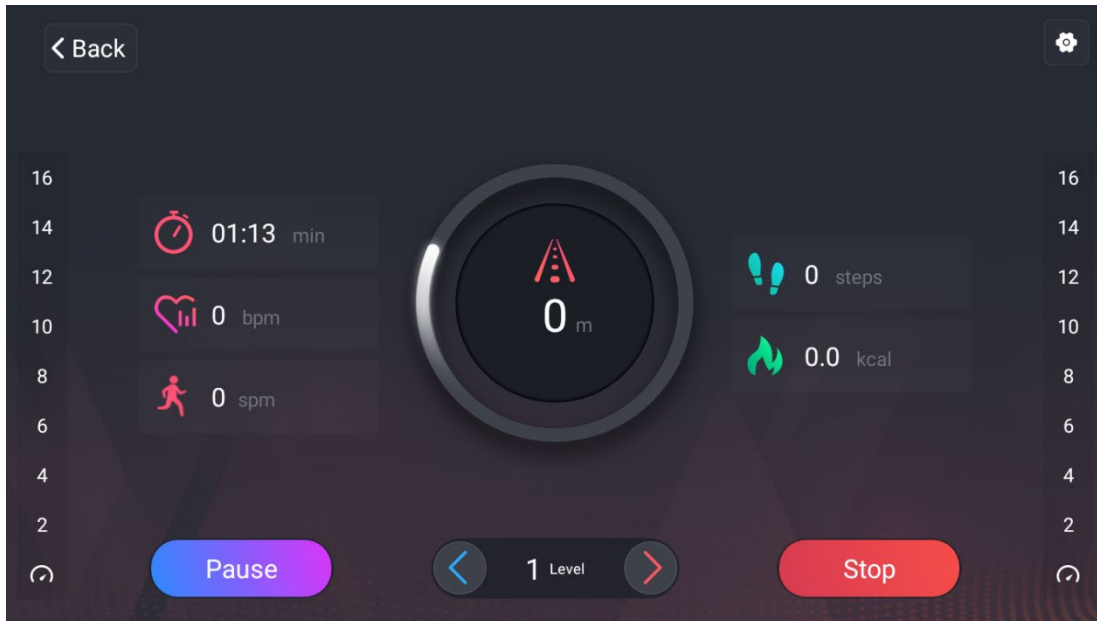

Exercise time	Heart rate	Cadence	Step counting	Calorie	Time out	Stop
Acceleration and deceleration gears	Fast speed gear adjustment			height		

4. Program motion

Click  icon, Go to the program motion interface (36 fixed programs built-in):

Set up any P1-P36 program, choose your exercise time and click Start.

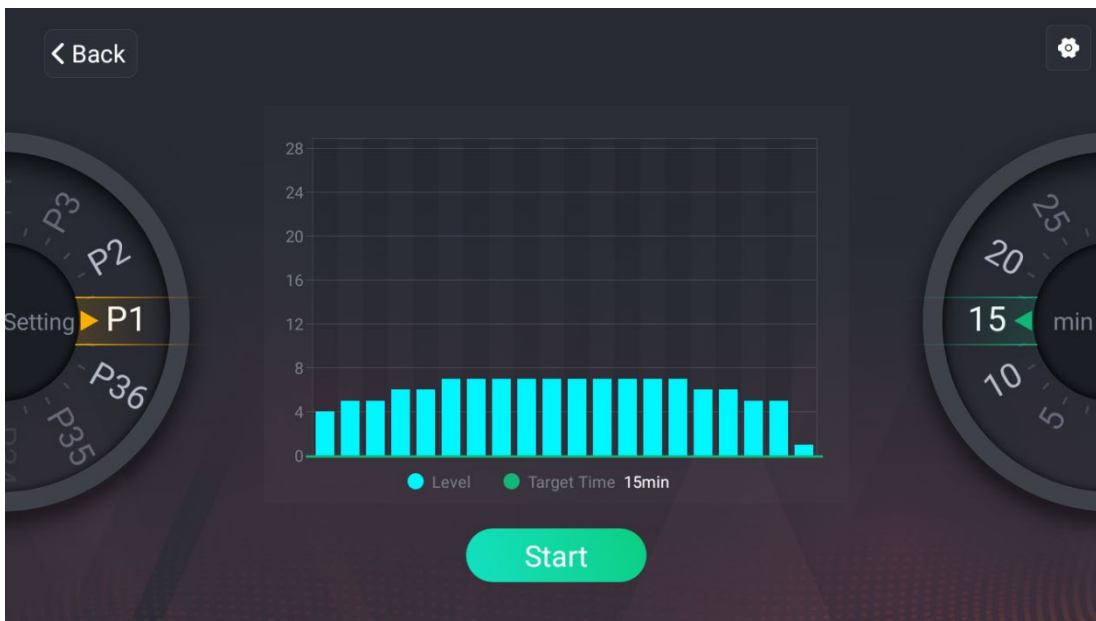

5. Sports center

Built-in 6 exercise modes: time countdown, calorie countdown, height countdown, step countdown, floor mode, custom.

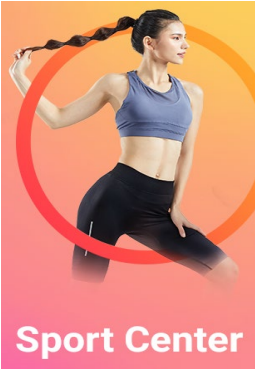
 <p>Sport Center</p>	<p>◆ Whether the speed is appropriate, there is a simple criterion for judging, that is, there is a feeling of sweating when exercising, but there is no feeling of not catching up and down, very uncomfortable, that is, the speed of this movement is the best.</p>
--	--

◆ Please be sure to check whether the emergency stop switch is effective before exercising. Any abnormal situation during the movement, shoot the emergency stop switch, and the ladder opportunity quickly decelerates to stop running;

- ◆ Please pay attention to your heart rate value at any time during exercise, the maximum heart rate value is controlled at 220 minus age (this is the limit value, general exercise does not exceed 90% of this value as well) every minute, if it is an older athlete, this number needs to be lowered;
- ◆ Any strenuous exercise, please do it after about 30 to 60 minutes after meals;



5.1 On the main interface interface, click "Sport Center" Go to the sports center management

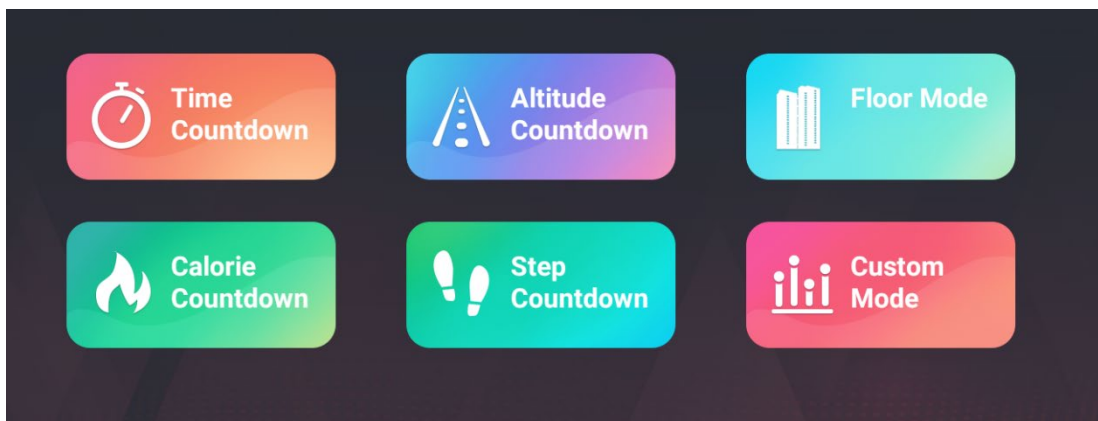

interface:

Users can choose the mode of movement according to their own sports goals;

Control catalog					
Time countdown	Calorie Countdown	Altitude Countdown	Step Countdown	Floor Mode	Custom Mode

For example; select Time Countdown

tap Time countdown icon, go to the time countdown settings page:

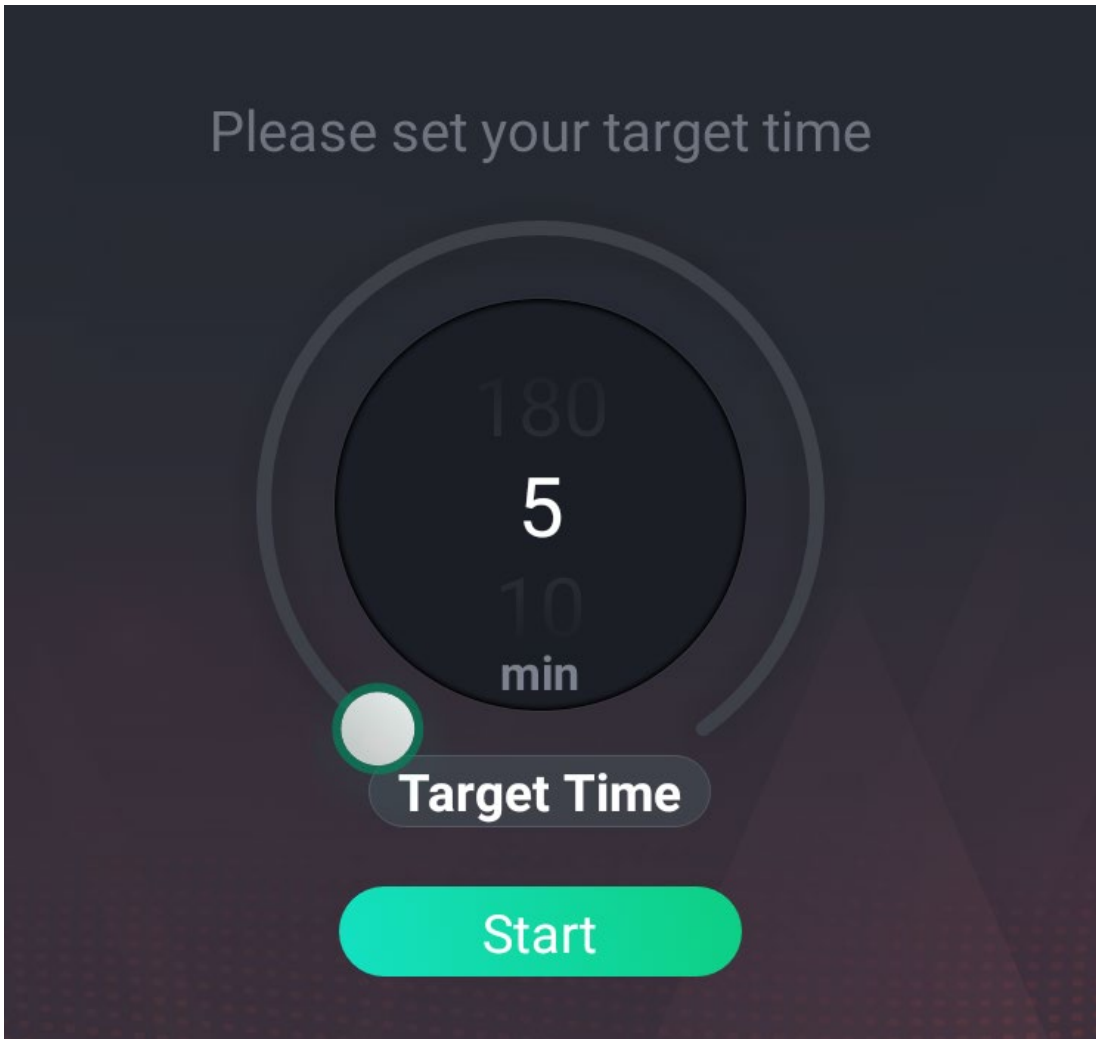

◆The user selects the movement time according to the needs, the built-in fixed time, the finger drags the circle button on the window or slides up and down the time value to set the movement time, once the setting is OK, click **Start** button, the movement begins;

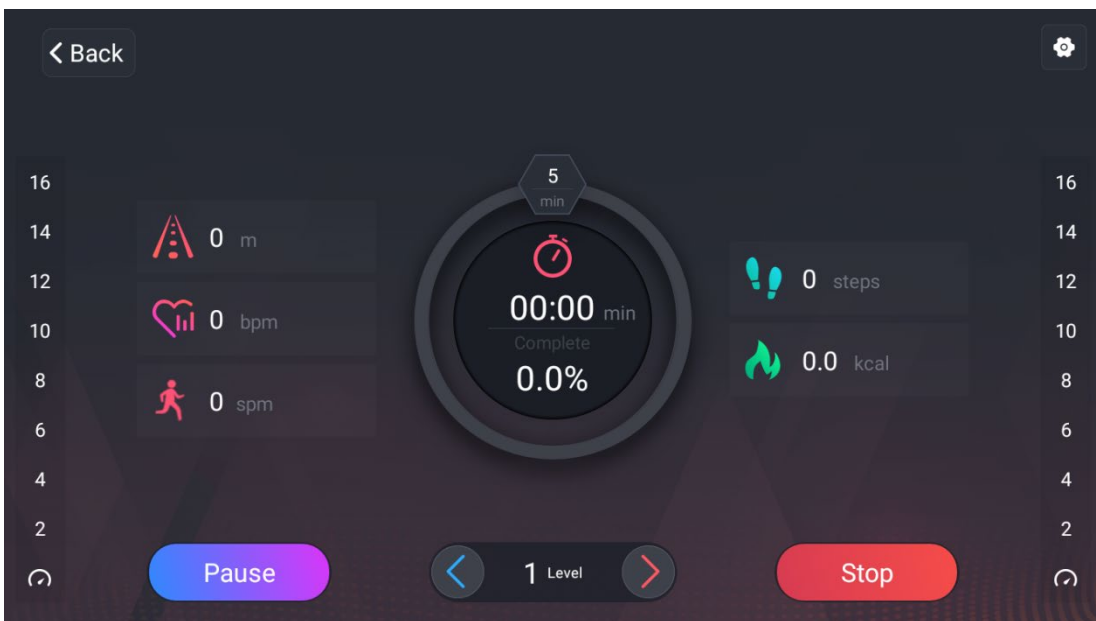

5.2 Click  Floor Mode icon, enter the Floor Mode Page:

Click Start to start floor mode

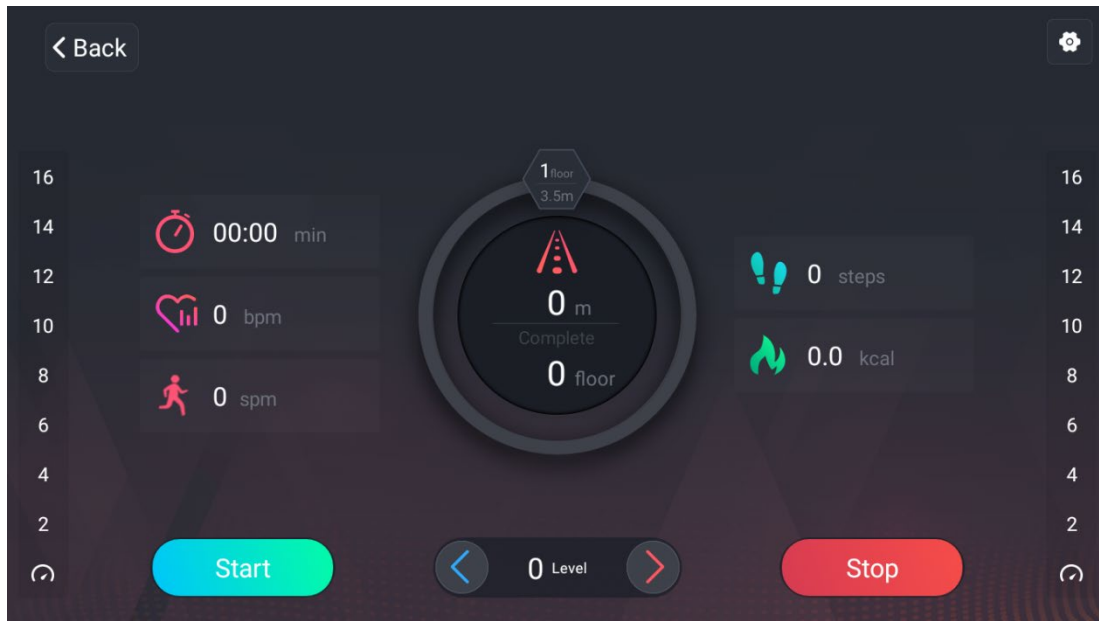

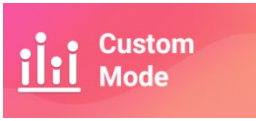
5.3 Click  Custom Mode icon to enter the customization settings

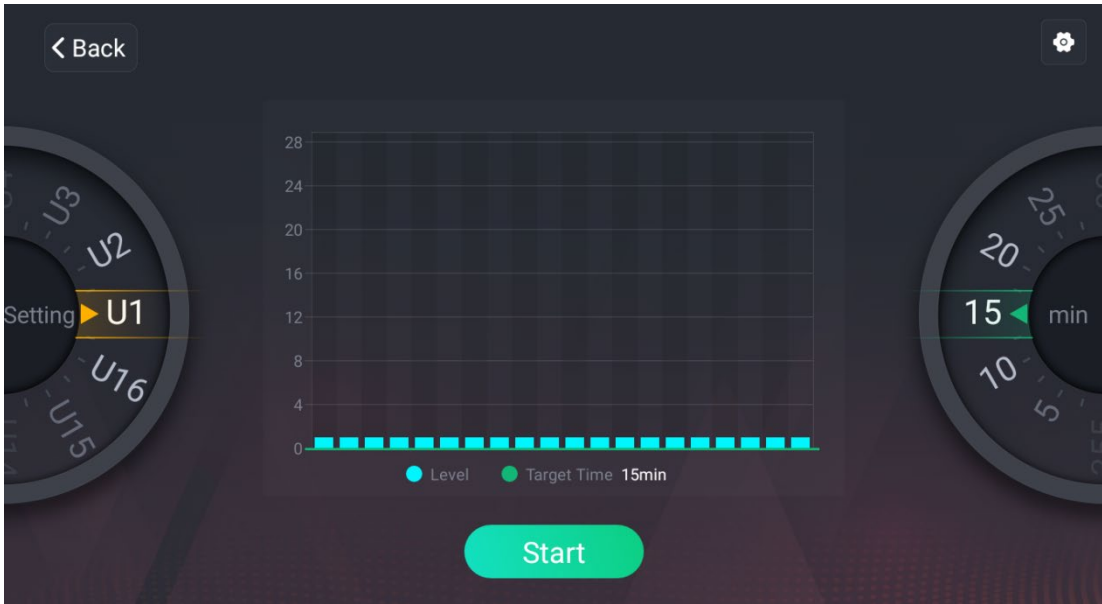

page:

控件目录	
	<p>Program list: Built-in U1-U16 A total of 16 program data can be selected by users;</p>
	<p>Coordinate chart: Represents the current gear, also drag up and down to set the speed gear, up to 25 stops.</p>
	<p>Adjust the time: the user slides up and down the time display box to customize the current motion time;</p>
	<p>Start: The user data setting is OK, click here, and the stepper starts to run;</p>



5.4

Press the stop button, the ladder machine smoothly slow down to stop running, the system will automatically calculate the results of this exercise, pop up the relevant report card interface.

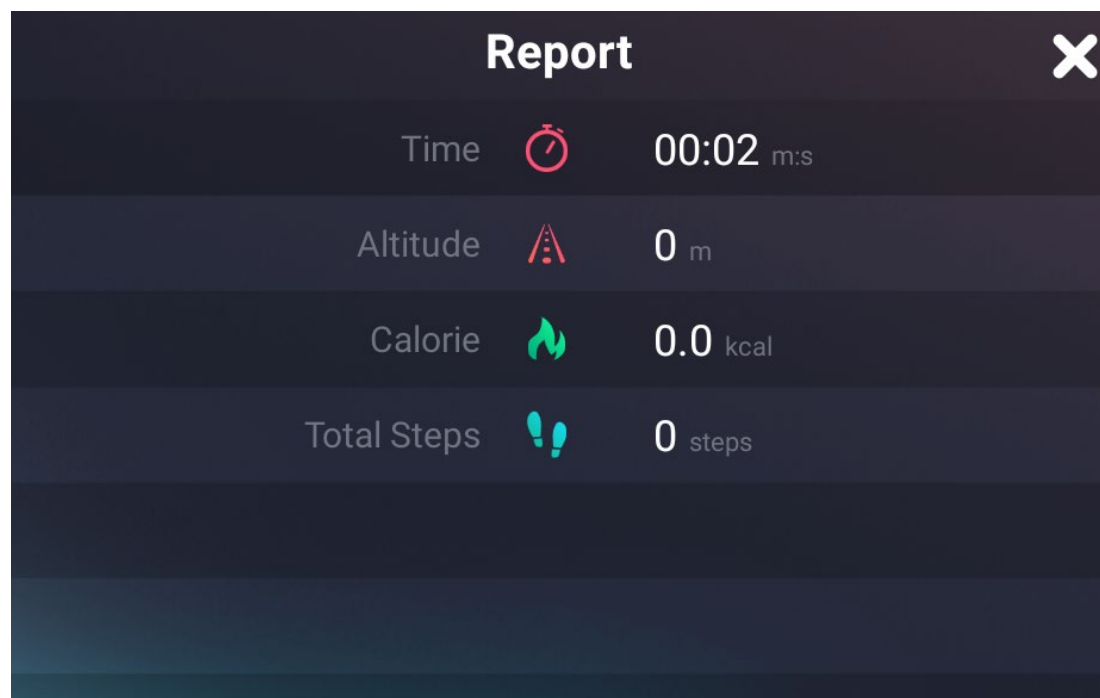

6. Set up

Built-in basic settings (brightness adjustment, volume adjustment, language selection, machine management, factory mode, one-click cleaning) and WIFI settings two major functions;

	<ul style="list-style-type: none"> ◆ The system will prohibit users from installing other APP applications to avoid crashing the stepper system; ◆ The system will prohibit users from uninstalling the built-in APP applications; ◆ Please clear the data and cache of the APP application regularly;
---	---



Click  Settings icon , enter the system settings page:

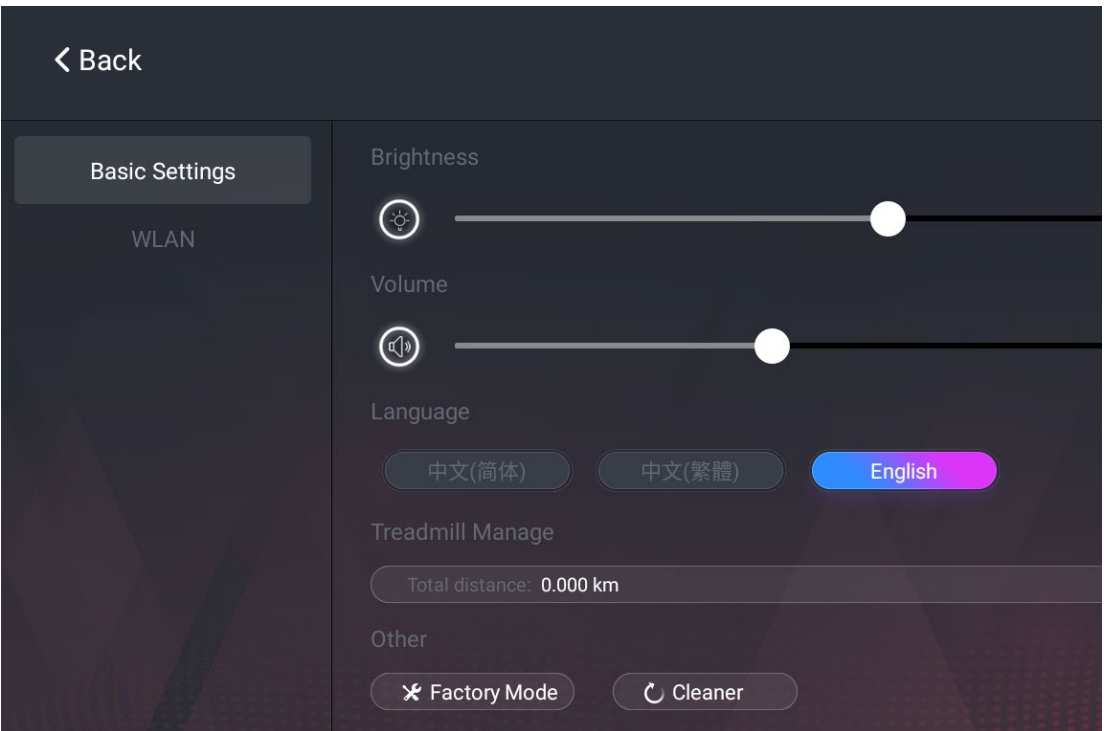

Click the  icon to set it up

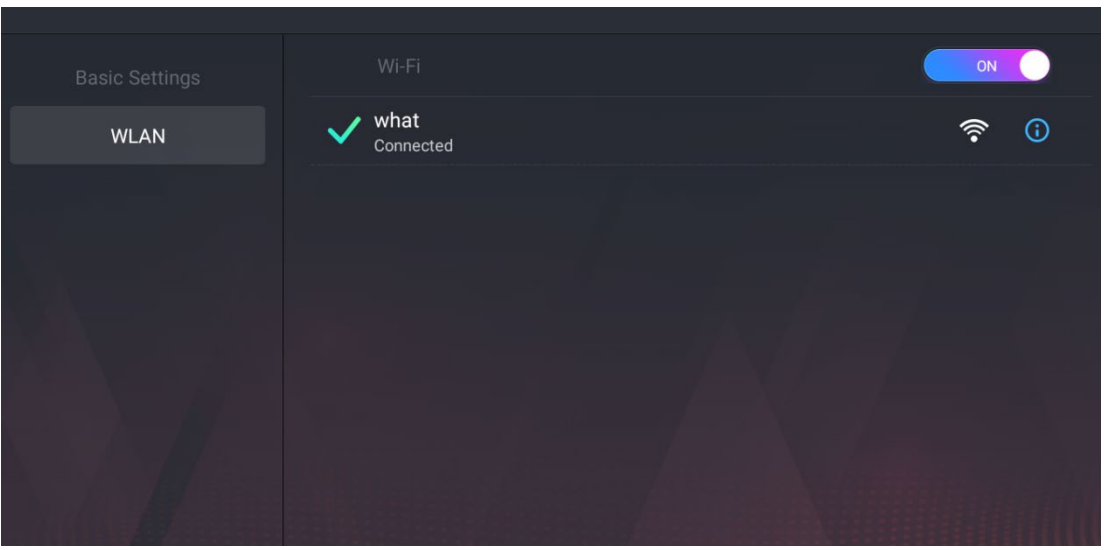

6. Precautions

- © In order to ensure the normal use of the equipment, please do not download the device;
- © Please regularly clean the cache of the device;
- © WIFI Restrictions: This product cannot link to WIFI that requires WIFI web page verification.
- © Unmanned automatic shutdown: This product has an unmanned shutdown function, when the equipment is in operation and no one is using, the ladder opportunity automatically stops.
- © Infrared emergency stop: When an object enters the infrared sensing area, the ladder opportunity immediately stops

GROUNDING METHODS

This product must be grounded. If it should malfunction or breakdown, grounding provides a path of least resistance for electric current to reduce the risk of electric shock.

This product is equipped with a cord having an equipment-grounding conductor and a grounding plug. The plug must be plugged into an appropriate outlet that is properly installed and grounded in accordance with all local codes and ordinances.

DANGER – Improper connection of the equipment-grounding conductor can result in a risk of electric shock. Check with a qualified electrician or serviceman if you are in doubt as to whether the product is properly grounded.

Do not modify the plug provided with the product – if it will not fit the outlet, have a proper outlet installed by a qualified electrician.

This product is for use on a nominal **220-volt** circuit and has a grounding plug that looks like the plug illustrated in **sketch A** in following figure. Make sure that the product is connected to an outlet having the same configuration as the plug.

No adapter should be used with this product.

Grounding Methods

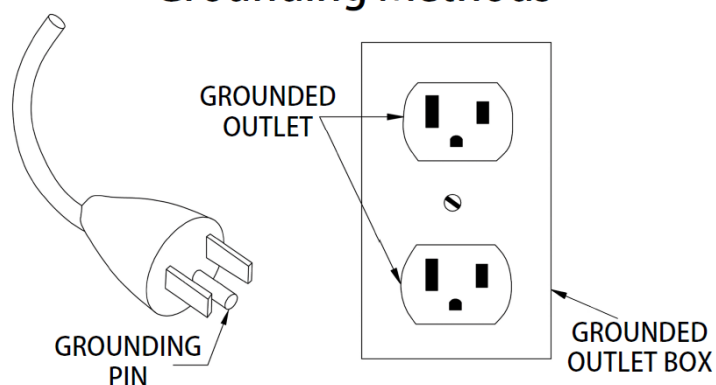

WARRANTY

DKN-Technology warrants this product to be free from defects in material at the time of the product's tender of delivery. This 'Carry-in' Limited Warranty applies for a period of two (2) years, beginning on the date mentioned on your product invoice or proof of purchase of product issue by DKN-Technology.

This Limited Warranty is not transferable and does not cover normal wear and tear (including, but not limited to, damage and wear to batteries, springs, bearings, running mats, hydraulic systems, ropes, belts, pulleys, power shocks, drive belts and other non-durable parts, etc...).

This Limited Warranty is void if the product is damaged by accident, unreasonable use, improper service, failure to follow instructions provided, modification from its original state, or other causes determined not arising out of defects in material, the consequences of improper treatment, bad installation, wrong assembly or tampering of the parts by incorrect assembly, improper use of the machine (eg. too heavy load in time, weight etc...), problems caused by lack of maintenance, deviations of the standard machine, such as light vibrations or noise, etc...

Transport charges, travel charges for technicians, and possible trader and/ or workshop charges are excluded from this warranty, and will be at the sole cost of the owner.

The liability of the manufacturer under this Limited Warranty shall not include any liability for direct, indirect, or consequential damages resulting from any defect nor the use of this machine.

CUSTOMER SUPPORT

Should you require any assistance regarding this product please gather the following information and then contact us using the details below:

- Product nr - This can be found on the product label
- Original purchase date
- Place of purchase
- Information about the place and conditions of use
- Precise description of the issue or defect









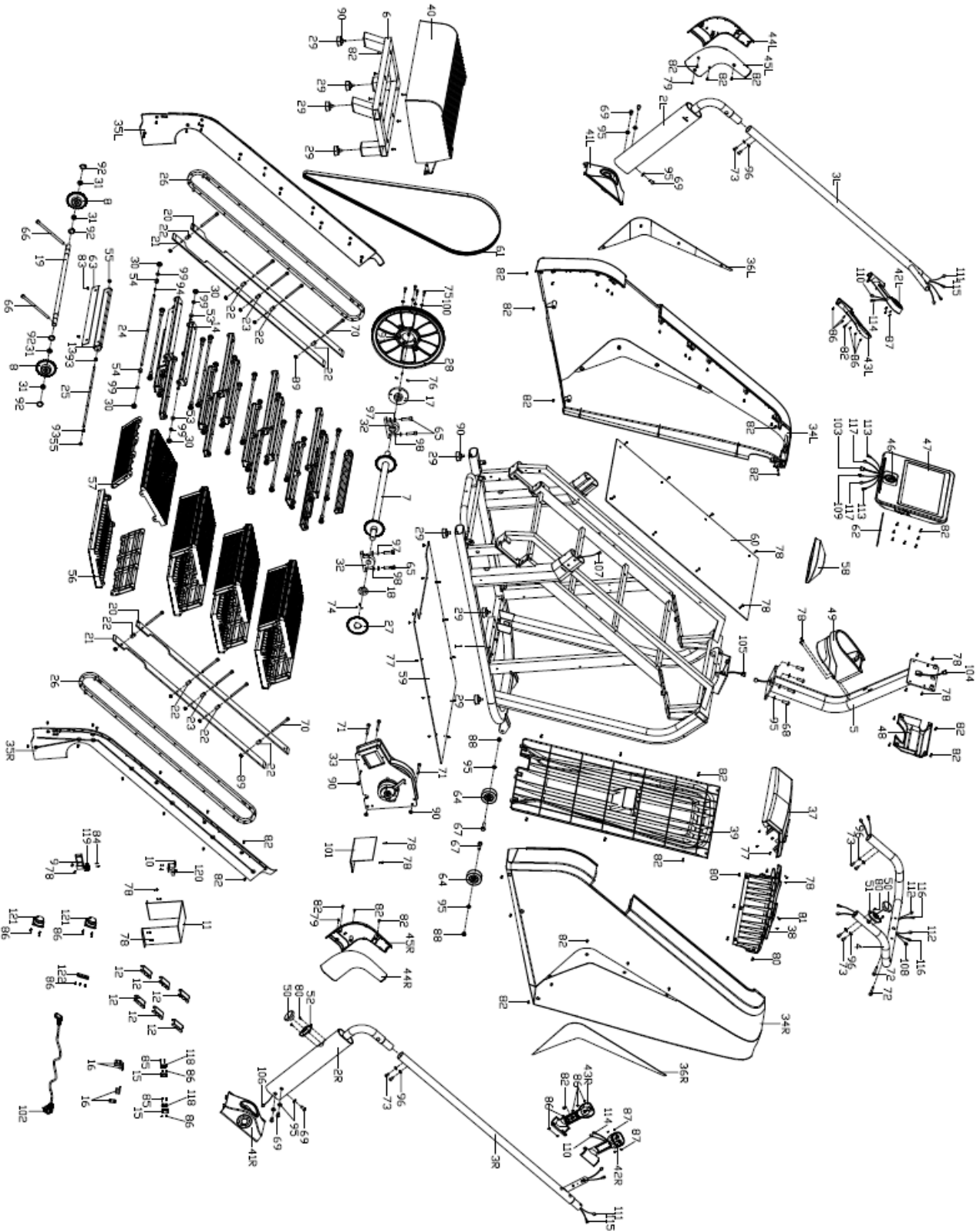



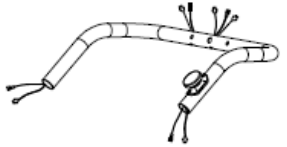

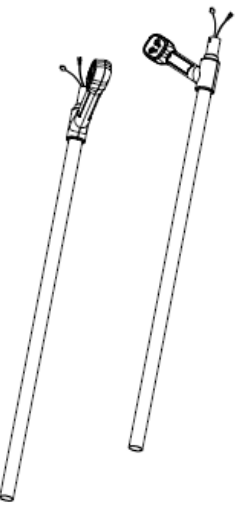

IMPORTANT!! - Please retain your sales receipt, DKN-Technology Customer Care may request proof of purchase to validate eligibility for warranty service.

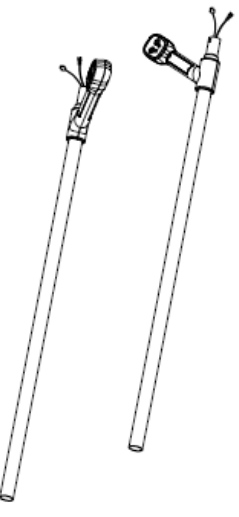
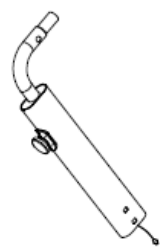
Warranty cover starts from the date shown on the proof of purchase.

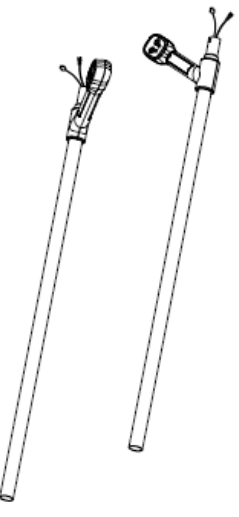
The best way to contact us is via www.dkn-technology.com.

EXPLODED DRAWING

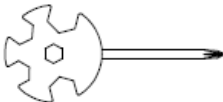
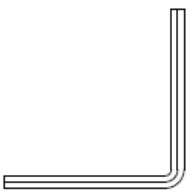
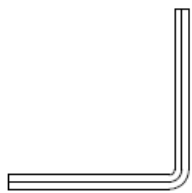

		
	#5 Console support column 1PC	#4 Rear handrail 1PC
		
	#41L/R Decorative cover 1Pr	#47 Console 1PC
		
	#2L Left Support column 1PC	#44L/R Exterior decorative cover
		
	#2R Right Support column 1PC	#45L/R Interior decorative cover
		
	#40 Pedal 1PC	#58 Decorative cover 1PC
		
#48 Rear decorative cover 1PC	#49 Bottle Holder 1PC	T shape Allen wrench 1PC
		
Cross wrench 1PC	Allen wrench (S=5) 1PC	Allen wrench (S=6) 1PC

PARTS LIST

Part No.	Description	Qty	Part No.	Description	Qty
1	Main frame	1	62	Anti slip pad	1
2L/R	Support columns	1 p.r.	63	EVA silencing pad	16
3L/R	Handrails	1p.r.	64	Roller	2
4	Rear handrail	1	65	Allen bolt M10 * 40	4
5	Console support column	1	66	Allen bolt M10 * 170	2
6	Rear pedal	1	67	Outer hexagon bolt M10 * 45	2
7	Front roller	1	68	Allen bolt M10 * 30	4
8	Rear gear	2	69	Allen bolt M10 * 20	6
9	Sensor fix tube	1	70	Allen bolt M8 * 105	10
10	Light sensor support	1	71	Allen bolt M8 * 75	3
11	PCB baffle	1	72	Allen bolt M8 * 40	2
12	Fixing plug	6	73	Large flat head bolt M8 * 15	8
13	Stair support 1	8	74	Flat end tightening M4 * 5	3
14	Stair support 2	8	75	Allen bolt M6 * 25	4
15	Infrared fastener	2	76	Flat end tightening M5 * 10	3
16	Cover fixing	4	77	Phillips screw w/cushion head ST4 *12	16
17	Pulley shaft sleeve	1	78	Phillips screw w/ washer head M4 * 15	24
18	Emergency stop disk sleeve	1	79	Phillips screw w/ washer head M4 * 8	2
19	Rear roller shaft	1	80	Phillips screw w/countersunk head M4*10	9
20	Guide	2	81	Phillips screw ST4 0*16	2
21	Guide2	2	82	Phillips screw ST4 0*16	90
22	Support sleeve 1	8	83	Phillips screw ST4 0*10	32
23	Support sleeve 2	2	84	Phillips screw M3 * 20	2
24	Bearing connecting shaft	16	85	Phillips screw m3 * 15	8
25	Step connecting shaft	8	86	Phillips screw ST2 9*9.5	27
26	Chain	2	87	Phillips screw ST2 2*8	8
27	Emergency stop plate	1	88	Nylon nut M10	2
28	Belt pulley	1	89	Nylon nut M8	10
29	Foot pad	8	90	Nut M8	11
30	Bearing 608Z	32	91	Nylon NUT M6	4
31	Bearing 6004	4	92	Outer snap ring Φ 25	4
32	KP005 pedestal bearing	2	93	Outer snap ring Φ 8	32
33	brake combination	1	94	C-type snap ring Φ 8	24
34L/R	Protective cover	1p.r	95	Internal serrated washer Φ 10*1.2	12
35L/R	Inner protective cover	1p.r	96	Internal serrated washer Φ 8*1.2	8
36L/R	Decorative strips	1p.r	97	Standard spring washer Φ 10	4
37	Upper protective cover	1	98	standard flat washer Φ 10	4

38	Upper protective cover 2	1	99	Flat washer Φ 8	32
39	Rear cover	1	100	Flat washer Φ 6	4
40	Pedal	1	101	Controller	1
41L/R	Decorative cover	1p.r	102	Power cord	1
42L/R	Upper cover	1p.r	103	Console upper wire	1
43L/R	Lower cover	1p.r	104	Console extension wire	1
44L/R	Exterior decorative cover	1p.r	105	Console lower wire	1
45L/R	Interior decorative cover	1p.r	106	Switch upper wire 1	1
46	Wireless charge module	1	107	Switch lower wire 1	1
47	Console	1	108	Switch upper wire 2	1
48	Rear decorative cover	1	109	Switch lower wire 2	1
49	Bottle Holder	1	110	Pulse upper wire	2
50	Emergency stop switch	2	111	Pulse extension wire 1	2
51	Switch base 1	1	112	Pulse extension wire 2	2
52	Switch base 2	1	113	Pulse lower wire	2
53	Step spacer 1	16	114	Key board Upper wire	2
54	Step spacer 2	16	115	Key board extension wire 1	2
55	Wear washer	40	116	Key board extension wire 2	2
56	Pedal 1	8	117	Key board lower wire	2
57	Pedal 2	8	118	Infrared sensor	2
58	Decorative cover	1	119	Distance sensor	1
59	Bottom baffle	1	120	Light sensor	1
60	Middle baffle	1	121	Speaker	2
61	Belt	1	122	USB / headset interface	1

WEBSITE



DKN[®]



dkn-technology.com



Make an Appointment to Visit our Showroom



sales@dkn-technology.com