



SMART LAT PULLDOWN

20812

OWNER'S MANUAL

WEBSITE



DKN[®]

Introduction



- | | |
|-------------------|-----------------|
| 1 Display | 2 Display Stand |
| 3 Resistance Unit | 4 Main Frame |
| 5 Leg Pad | 6 Seat Pad |

Installation Indication

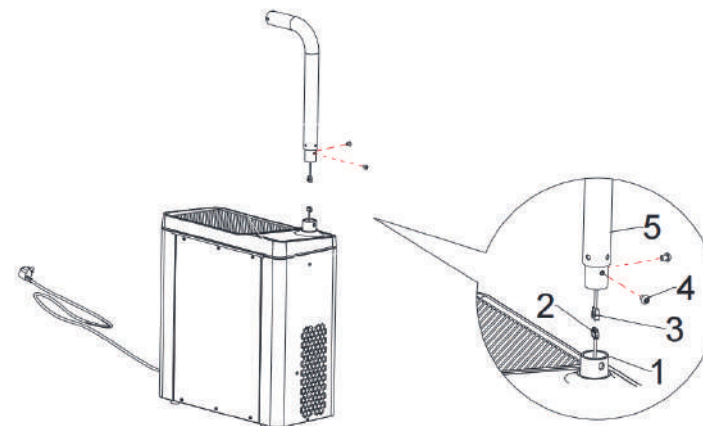

As shown in the diagram:

1. Stand base
2. Base communication terminal
3. Stand communication terminal
4. M8*10 internal hexagon socket button head screw
5. Display stand

Step 1: First, insert the base communication terminal (2) into the stand communication terminal (3) as shown in the diagram.

Step 2: Next, insert the display stand (5) into the stand base tube (1)

Step 3: Finally, use the M8*10 internal hexagon socket button head screw (4) to securely fasten the stand base (1) and the display stand (5)

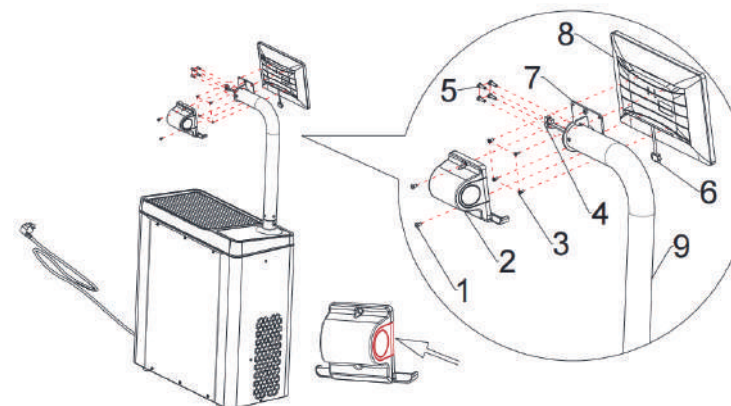

As shown in the diagram:

- 1: Cross recessed pan head screw M4*8
- 2: Display back cover
- 3: Cross recessed pan head screw M3*6
- 4: Stand communication terminal
- 5: Cross recessed pan head screw M4*16
- 6: Control communication terminal
- 7: Screen fixing seat
- 8: Display
- 9: Display stand

Step 1: First, use the cross recessed screw (5) to fasten the screen fixing seat (7) and the display stand (9) together (note: the notch on the screen fixing seat should face upwards).

Step 2: Next, use the cross recessed screw (3) to fasten the display (8) onto the screen fixing seat (7).

Step 3: Connect the stand communication terminal (4) and the control communication terminal (6) together. Then, attach the display back cover (2) as indicated by the arrow in the diagram. Use scissors or a blade to trim off the excess part (note: be careful not to cut the wrong side and watch out for sharp edges after trimming). Finally, use the cross recessed screw (1) to fasten the display back cover (2) onto the screen fixing seat (7) (note: be careful not to press on the communication wires during this process).

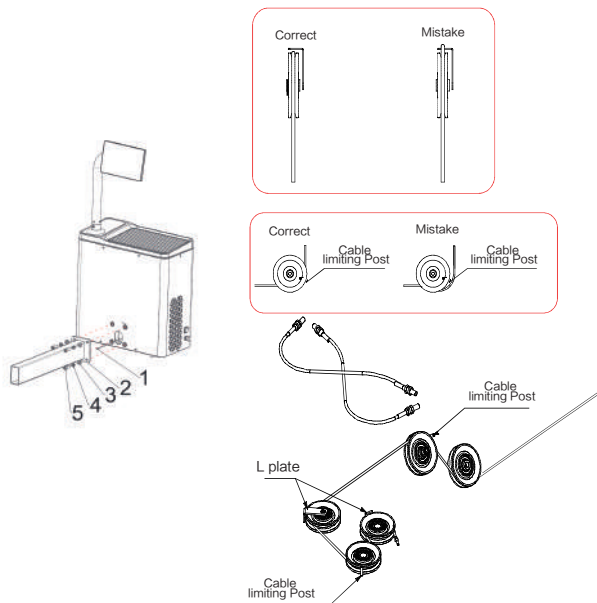

As shown in the diagram:

- 1: Cable
- 2: Connecting pipe
- 3: M12 flat washer
- 4: M12 spring washer

Step 1: First, power on the device (do not operate the interface). Pull out the steel wire rope (1) to a length of approximately 2.8 meters. Hold onto the steel wire rope to ensure that there is more than 2.8 meters of length outside. Then, turn off the power supply. Next, follow the cable routing of main frame shown in the left diagram, pass the cable through the pulley inside the pipe, and finally, use the M12 flat washer (3), spring washer (4), and hexagon screw (5) to connect and secure the chassis and the main frame.

Safety Precautions

Thank you for choosing the commercial digital strength training equipment . The correct use of the product is the guarantee of safety exercise. To protect the personal safety of you and your family during exercise, please read this manual carefully before using the product, and strictly follow the precautions in the instructions when using.

1. Carefully read this instruction manual before use, and install and use the equipment according to the instructions in the manual. Do not change or dismantle the equipment arbitrarily.
2. Ensure that trainers fully understand the safety warnings and precautions on the equipment before use.
3. Do not wear excessively loose clothing when using the equipment. Wear sports shoes during training.
4. Before using the equipment, carefully inspect the training device. If any damage is found, do not use it and do not attempt to repair the machine by yourself. Notify the after-sales service for repair as soon as possible.
5. The equipment should be placed indoors and ensure that the ground is flat. There should be sufficient space around the equipment for trainers to use the machine freely.
6. Before use, check the cables to ensure that they are on the pulleys and pay attention to the ends of the cables.
7. Children and pets are not allowed near the training equipment during using.
8. If a trainer experiences dizziness or body pain during training, they should immediately stop exercising and consult a doctor.

9. Please make sure to read all instructions before use. The factory is not responsible for any personal injury or property damage caused by improper use of this product.

10. The power plug must be reliably grounded, and try to avoid using other electrical appliances on the same power supply line. Please do not use a damaged or wet power cord or plug. The power cord is dedicated. If damaged, it must be replaced by the manufacturer, service center or personnel with relevant professional qualifications to avoid injury.

11. Confirm that the grounding of the console is good: Use a digital multimeter set to the AC mode to measure the voltage difference between the live wire and the ground wire, as well as between the live wire and the neutral wire. For a three-pin plug, measure the voltage difference between the live wire and the neutral wire, and between the live wire and the ground wire. If the voltage difference between the live and ground wires is equal to or slightly higher (5V) than the voltage difference between the live and neutral wires, it indicates good grounding. If it is zero, it means that the ground wire is not connected. If the voltage is lower than the voltage difference between the live and neutral wires, it indicates poor grounding and the presence of ground resistance.

12. To confirm whether the equipment's grounding connection is good. Please use a digital multimeter and set to the short circuit mode. To touch the red probe to the product's ground wire and the black probe to the iron frame. To listen whether it has a buzzing sound. If there is a sound, it indicates good grounding connection. On the contrary, there is a problem to grounding connection.

13. Do not plug the machine into a socket with a short circuit or leakage grounding to avoid electric shock.

14. If you feel any discomfort or abnormality while using the equipment, please stop exercising immediately and consult the instructor.

15. Individuals aged 65 and above, those trying to conceive, pregnant women, breast-feeding mothers, those who have undergone surgery within the past 6 months, individuals with diseases such as heart disease, hypertension, asthma, or other conditions that prohibit vigorous exercise as advised by a doctor, are not recommended to use this equipment. If you are currently using it, please stop immediately.

16. It is strictly prohibited to consume alcoholic beverages or any stimulant products that are prohibited by national laws and regulations before and after use.

17. Fatigue, improper use, and excessive exercise may potentially cause harm. Before engaging in fitness activities, accurately assess your physical condition and endurance, and ensure that the fitness movements, intensity, and duration are appropriate.

18. Minors must use this equipment under the supervision and guidance of a guardian and are not allowed to use it alone.

Operating Instructions

Preparation before use:

The product needs to be powered on for use. Before powering on, do not pull out the rope. If the rope is accidentally pulled out without power, please turn on the power station. After turning on, the rope will automatically retract.

Power on/off:

Insert the power cord into the power socket (16A). After inserting, press the power switch downward to turn on the power station: " _ " on the power switch indicates power on, and "0" indicates power off.



Operation Manual

Mode Description:

We provide four resistance modes for the product, namely Standard Mode, Eccentric Mode, Isokinetic Mode, and Elastic Mode. Please refer to the following instructions for specific modes:

Mode	Code	Instruction
Standard Mode	1	•The standard mode means that the resistance of pulling up and returning is the same. For example, if you choose 10KG, the resistances of centripetal and eccentric movement are both 10KG.
Eccentric Mode	2	•Eccentric mode means that the resistance is greater when the rope is put back, and the resistance is less when the rope is pulled up. •The set weight is the weight of the eccentric stage of putting back the rope. For example, if you set 10kg, the eccentric stage of pulling up is less than 10kg, and the eccentric stage of putting it back will have 10kg. This mode can provide you more impactful training weight, and more stimulation for your muscles.
Isokinetic Mode	3	•In the isokinetic mode, the resistance will change dynamically with the force you exert. When the device feels that you are exerting a lot of force, it will increase the resistance to ensure that the speed at which you pull is as close to a constant speed as possible, so that muscles are fully stimulated throughout. We provide different speed levels of 0.1–1.0m/s to meet your different resistance and speed requirements. •When your pulling speed is lower than or equal to the set speed, the resistance is relatively constant; when you pull faster than the set speed, the resistance will increase and your movement speed will decrease.
Elastic Mode	4	•Resistance is similar to the elastic band, the longer the pull-out length, the greater the resistance. •In the elastic mode, the resistance feeling of pulling the power station is similar to that of the elastic band. •The longer the pull-out length, the greater the resistance; With different training levels, even when the length of the rope is the same, the resistance will be different.

LED Light Description :

State		Color	Remark
Powered on, resistance not activated		Blue	Gradient effect (dark to light, light to dark)
Start up	Maximum resistance Below 40%	Green	Always on
	Maximum resistance 40%–70%	Yellow	Always on
	Maximum resistance More than 70%	Orange	Always on
Fault		Red	Always on

Installation Precautions

1. When removing the packaging on the surface of the packaging equipment, be careful not to scratch the surface of the machine with a knife. There must be enough personnel when moving equipment to prevent equipment from colliding or personal injury caused by insufficient personnel.
2. Before installation, make sure that all equipment parts are complete and there are no missing spare parts .
3. When installing the equipment, it must be assembled by more than two people to ensure that the assembly positions of the components are accurate.
4. Please pay attention to the installation steps when installing to prevent incorrect installation or leakage of installation.
5. Use appropriate installation tools to avoid using inappropriate installation tools that may cause equipment damage or cause injury to the installation personnel.
6. If the equipment needs to be moved, it can only be moved after the installation is complete. The equipment cannot be moved during the installation process or when the nuts are not locked.

7. Pay attention to the order of locking nuts when installing. Do not lock the nuts being installed until the entire equipment is installed. Only lock the nuts one by one after the entire machine is installed.

8. Check the terminal part of the steel cable before installation to check whether the terminal is firm.

9. After installation, use gentle force when testing the equipment for the first time, and then use it normally after confirming that there is no abnormality in the equipment. If any abnormality is found in the equipment, check the equipment carefully to find out the problem and reinstall it.

Specification

Model	20812
Resistance Pack model	B
Dimension (mm)	1640 × 1470 × 1900mm
Display size	10.1 inch
Net Weight	145kg
Gross Weight	172kg
Resistance Motor Output	130 kg
Precision Adjusting	1kg
Rated voltage	AC220-240 50-60Hz
Max Loading Weight	180kg
Operation Temp	0°C~35°C
Operation Humidity	10%~90%

Assembly Step 1

Step	NO.	Description	Specification	Qty
1	73	Hexgon socket	M10*35	3
	78	M10 Pain washer	Φ20*Φ10.5*2	3
	81	Spring washer	M10	3
	101	Main frame		1

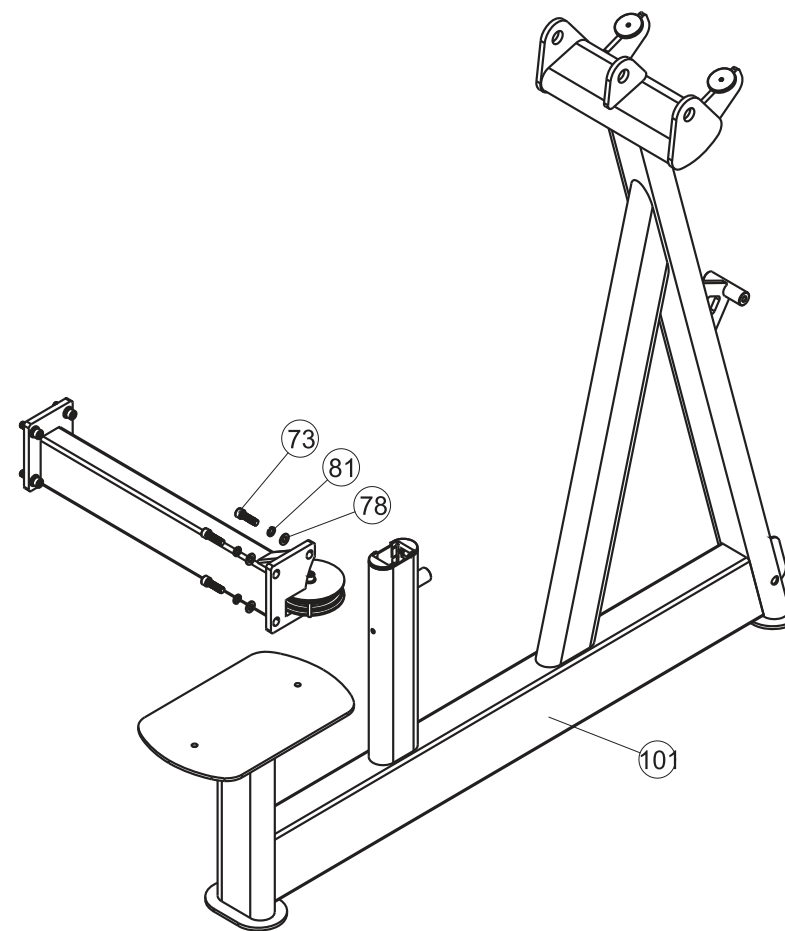

Assembly Step 2

Step	NO.	Description	Specification	Qty
2	35	Connection shaft		1
	39	Left pulldown frame		1
	40	Right pulldown frame		1
	51	Plastic washer		4
	69	Circlips for shaft	DO-25	2

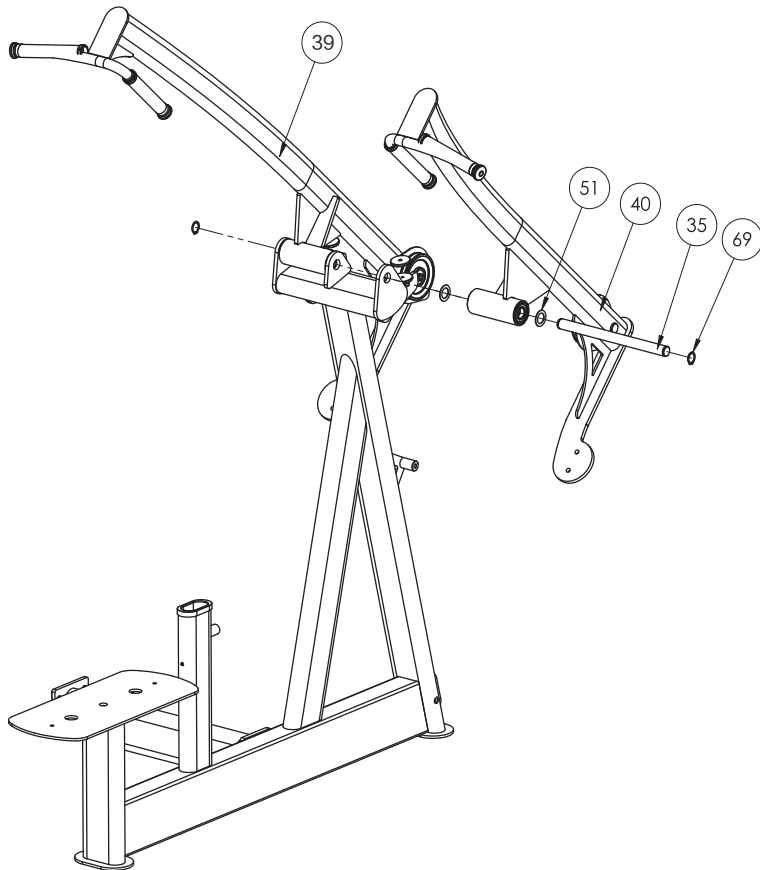

Assembly Step 3

Step	NO.	Description	Specification	Qty
3	43	Counter weight		2
	75	Hex socket head cap screw	M10*85	4
	78	Plain washer	Φ20*Φ10.5*2	8
	83	Nylon insert lock nut	M10	4

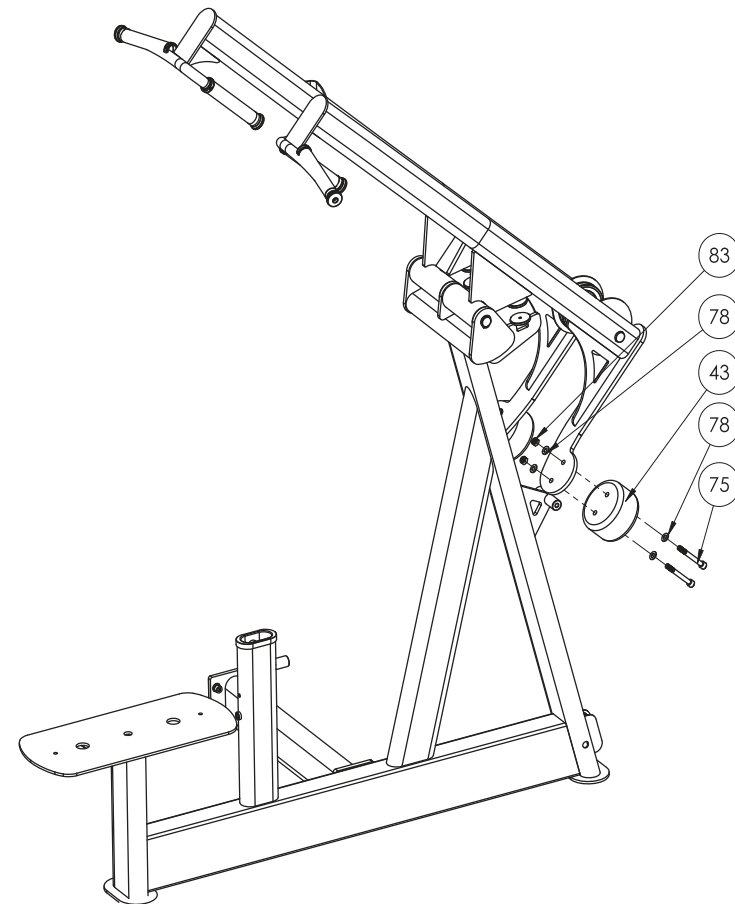

Assembly Step 4

Step	NO.	Description	Specification	Qty
4	97	Thigh pad adjusting frame		1

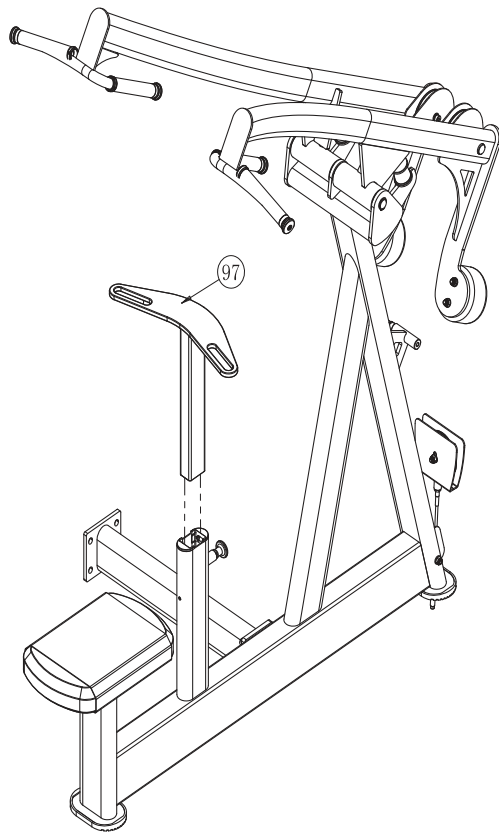

Assembly Step 5

Step	NO.	Description	Specification	Qty
5	46	Shoulder pad subplate		2
	47	Nylon subplate		4
	48	Aluminum bush		4
	63	Limiting screw		1
	73	Hex socket head cap screw	M10*35	4
	79	M10 Big washer	Φ25*Φ10.5*2	4
	81	Spring washer	M10	5
	82	Two-sided gear washer	Φ10.5*Φ16*1	4
	85	Shoulder pads		
	87	Countersunk hex socket screws	M8*30	4

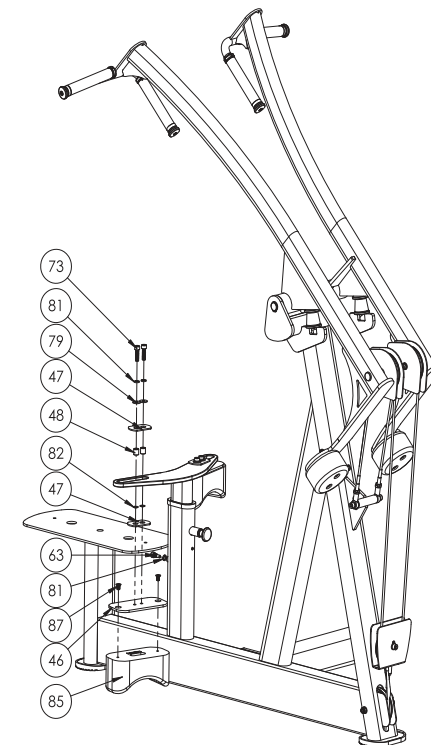

Assembly Step 6

Step	NO.	Description	Specification	Qty
6	34	Cable Set 2	$\phi 6.3$	1
	36	Cable set 1	$\phi 6.3$	1

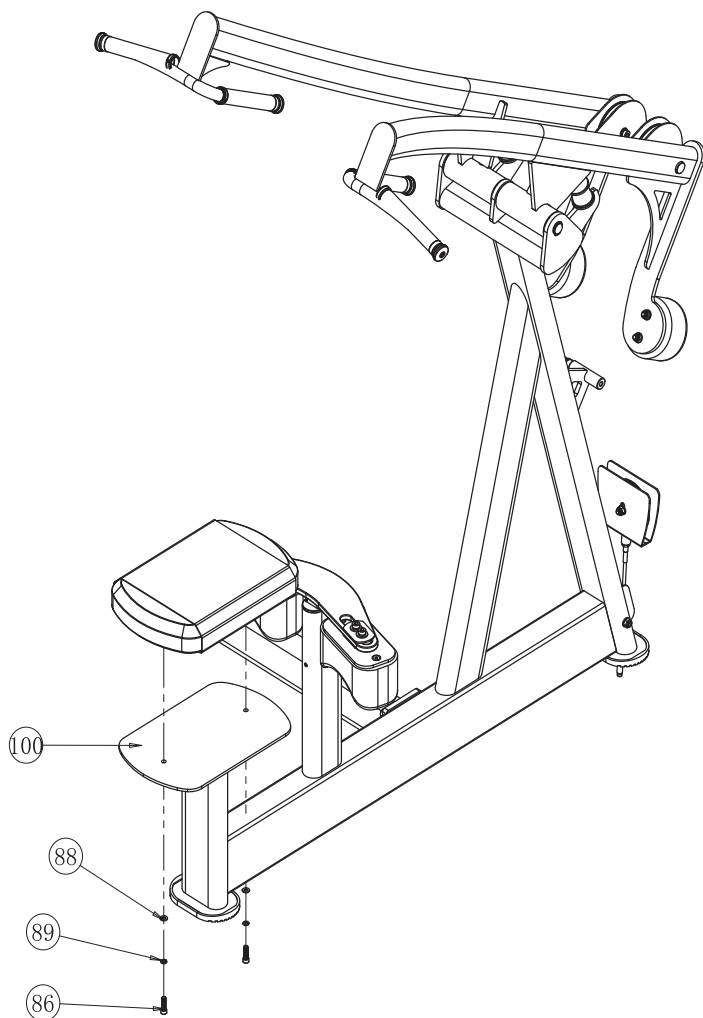

Assembly Step 7

Step	NO.	Description	Specification	Qty
7	86	Hex socket head cap screw	M8*30	2
	88	M8 Plain washer	$\Phi 16*\Phi 8.4*16$	2

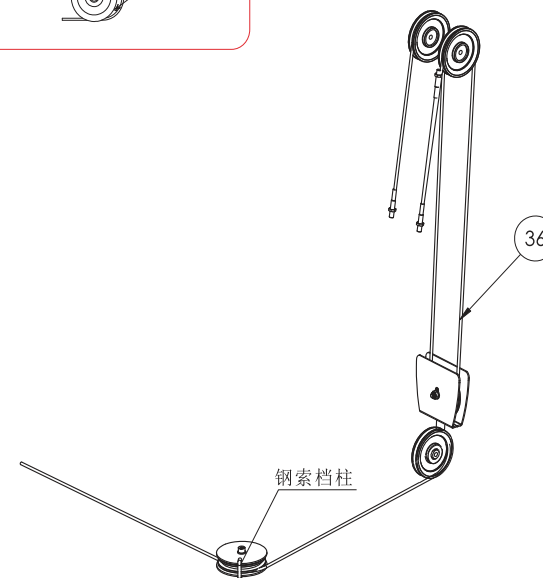
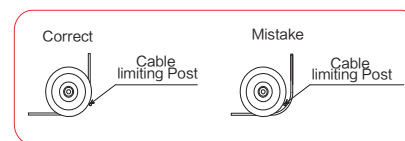
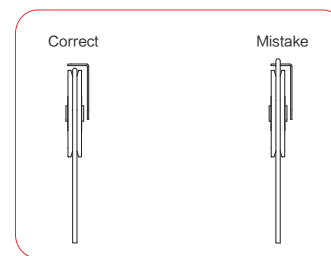

Assembly Step 8

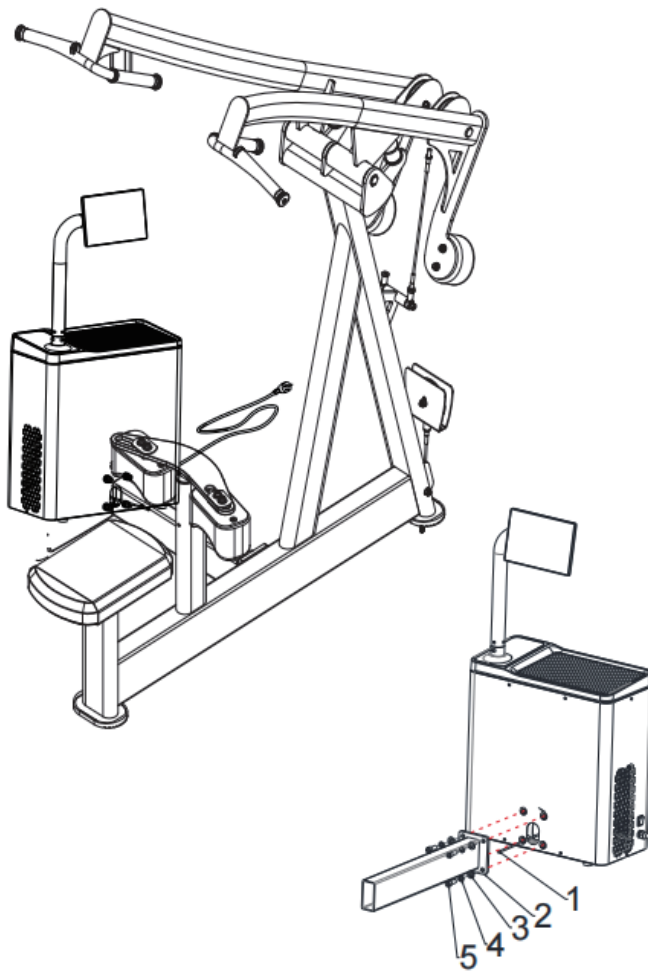

Maintenance Attentions

Daily Maintenance:

- 1.Clean the seat pad,back pad and cushion with warm water and soft cloth in order to avoid the sweat erosion to these component .
- 2.Clean the frame with warm water and soft cloth
- 3.Cleaning chrome plated parts:wipe them with alcohol moistened soft cloth

Monthly Maintenance:

- 1.Check transmission cable .Check the tightness and abrasion of the cable (disrepair of the surface,bend ,distortion and so on).
- 2.Check pulley on whether its groove surface is clean and whether it runs smoothly .
- 3.Check bolts and fixing parts.Wipe them with alcohol and anticrrrosive oil .

Further Maintenance:

- 1.Check whether bolts on basic frame become loose,springs have damaged and the tightness of drive cable.
- 2.Check,if there is rust or paint loss on mainframe and basic rack,clean out rust by sandpaper,and then cover it with same color paint from the same supplier.
- 3.Clean and lubricate every bearing,and keep equipment work smoothly.
- 4.Check whether the oil cylinder suffers oil leakage.
- 5.Check whether any damage to the rubber pad.